

# RhinoTuff HD-e4100 Econ-O-Roll Coil Inserter

## Instruction Manual



Provided By

**MyBinding**.com®  
*When Image Matters.*

# HD-e4100 Econ-O-Roll Coil Inserter Operator's Training Manual



Issue "0" 12/06  
PDI Part # 941005

Performance Design Inc.  
2350 East Braniff St.  
Boise Idaho 83716

***This manual contains very important safety information  
and must be read!***

## **HD-e4100 Operator's Training Manual**

### **Issue "0" 12/06**

The HD-e4100 Econ-O-Roll Coil Inserter will greatly increase productivity. An in-depth look at the set up procedures necessary to achieve maximum results follows.

The HD-e4100 Econ-O-Roll Coil Inserter can attach to the HD-6500, HD-7000, HD-7700, OD-4000, and OD-4012 Rhin-O-Tuff punches and can also stand alone. This manual discusses all of the necessary steps to use and care for your machine.



## Table of Contents

Chapter: Number:	Page
1) Important safety notice!	4
2) Overview of your HD-e4100 Econ-O-Roll Coiler.	5
3) Placing the HD-e4100 in the proper location & Binding Styles.	6
4) Detailed Use of the HD-e4100 Econ-O-Roll.	6
5) Cleaning the HD-e4100 Econ-O-Roll.	8
6) Product Registration.	8
7) Optional Binding Station Accessories.	8

### 1) Important Safety Notice!



Make sure you read this section very carefully! Learn to recognize this **Safety Alert Symbol**. The HD-e4100 Econ-O-Roll Coil Inserter has been designed to provide a very high level of protection to an operator. Follow the guidelines below while installing, operating and maintaining your machine. Read this manual and keep and file this manual for future use.



- Always replace fuses with the correct amperage and type (PDI P/N 001763 115VAC or 001664 230VAC);
  - ✓ 115VAC use; 1ea. FUSE, 1 AMP 1/4 X 1 1/4 MDL-1-R
  - ✓ 230VAC use; 2ea. FUSE, 1 AMP M5 X 20 GMA-1-R

Refer to the serial number label on the rear of the machine to determine the voltage of your machine.



Serial Number Label Example.



- If the machine runs erratically or if the wheel stops turning while the machine is on, unplug the HD-e4100 and call your dealer immediately for service.



- Never attempt to service your machine unless you are a qualified technician. There are no user serviceable parts inside the HD-e4100 Econ-O-Roll Coil Inserter.



- Never operate the HD-e4100 Econ-O-Roll Coil Inserter if the provided power cord does not fit your outlet. Power cord shall be certified for the country where the machine will be installed.

## 2) Overview of the HD-e4100 Econ-O-Roll;

See Fig. A. The HD-e4100 has many useful features to increase your coil binding productivity:

- 1- **Adjustable Lower Roller:** The Adjustable Lower Roller supports the lower side of the coil while binding. It has 3 positions. Top position is for 5MM to 13MM coil, middle position is for 14MM to 22MM, and the bottom position is for 23MM to 50MM coil.
- 2- **Doc-U-Form Book Former:** allows you to form your book to allow for quick starting and binding of large books.
- 3- **Upper Roller:** The soft Upper Roller grabs the coil and spins it into the book quickly and effectively.
- 4- **Left Handed Coiling Position:** By moving the Adjustable Lower Roller into this position and coiling from the back of the HD-e4100 provides for Left handed coiling. Left Handed Coiling is a NEW Feature!
- 5- **Rear Doc-U-Form book Former:** Used with Left Handed Coiling.
- 6- **Power Switch:** This switch turns the HD-e4100 on and off. Pushing on the **I** symbol side of the switch turns the machine **ON**, the **O** turns the machine **OFF**.
- 7- **Power Cord:** In case of any emergency use the power cord as the main power Cutoff!!!
- 8- **Fuse Holder:** Always replace fuses with the correct amperage and type (PDI P/N 001763 115VAC or 001664 230VAC);
  - ✓ 115VAC use; 1ea. FUSE, 1 AMP 1/4 X 1 1/4 MDL-1-R
  - ✓ 230VAC use; 2ea. FUSE, 1 AMP M5 X 20 GMA-1-R



Fig. A

### 3) Placing the HD-e4100 in the proper location & Binding Styles;

Locate a clear work area with an outlet within 5 feet that provides a 15-amp service (16-amp European) which is protected at the customer's circuit box. The work area must be a solid, firm cabinet or a heavy duty table with a flat level surface. Power cord shall be certified for the country where the machine will be installed.

Placing your HD-e4100 Econ-O-Roll Coiler in the proper location will also depend on your binding technique. If your binding technique is to punch and stack the entire job before coiling, then positioning the HD-e4100 away from your punch for more work area may be the best setup as well as leaving the HD-e4100 on its stand-alone feet as supplied. However if your technique is to punch and coil a single book at one time and repeat until the job is complete then mounting the HD-e4100 Coiler directly onto your punch may be the best setup for you. Please see your dealer for mounting kits.

### 4) Detailed Use of the HD-e4100 Econ-O-Roll;

**3.1) Doc-U-Form Book Former.** See Fig. B. Turn the machine on. The Doc-U-Form Book Former (1) shapes the binding end (2) of your book (3) so that insertion and starting of the coil (4) is simple to do. Gently jog your book onto the Book Former until formed. Then start the coil into the first 5 holes or more by spinning it by hand.

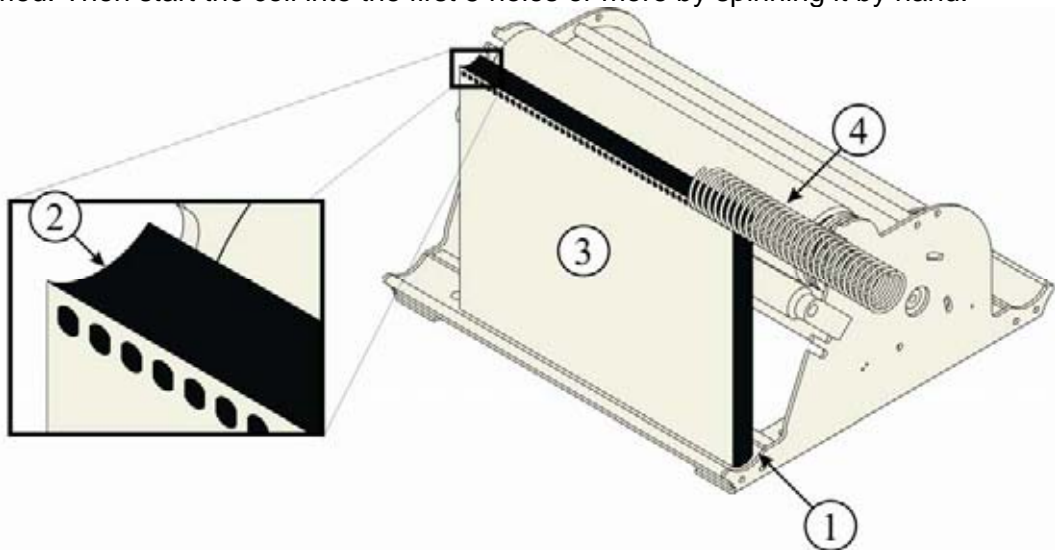

Fig. B

**4.2) Coiling.** See Fig. C. Once the coil has been started, using both hands, rotate the book (1) so that it is level to the table surface. While holding the book close to the binding edge so that the pages and holes stay aligned, set the coil on top of the Lower Roller (2) and lightly “bump” the coil against the Upper Roller (3) so that the HD-e4100 will spin the coil into the book. It may be preferred to pull the left end of the book away from the Upper Roller (4) allowing the right end of the Upper Roller (3) to do all the spinning of the coil, but you may find other techniques work well also. In the next section a new technique/feature is described. This new technique/feature is Left handed coiling.

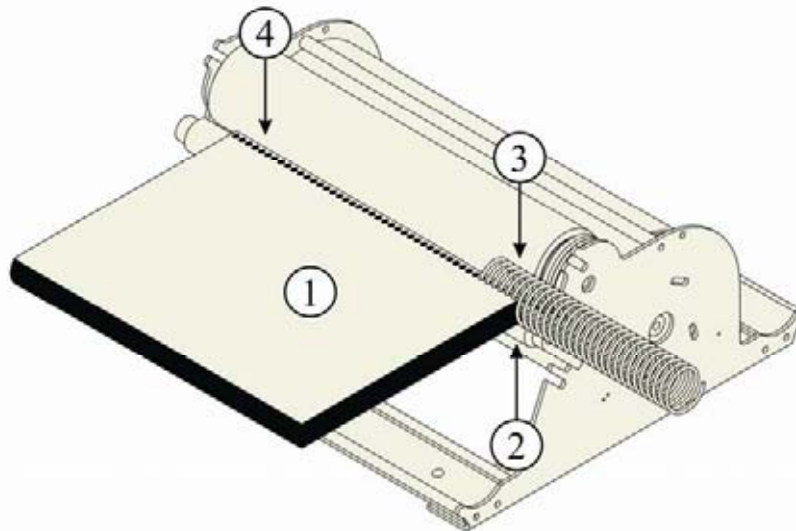

Fig. C

**4.3) Left handed Coiling.** See Fig. D. Before Left Handed Coiling, turn your HD-e4100 around so that the Rear Forming Bar faces you (1). Use the Rear Forming Bar to form your book and start your coil from the Left (2). Once the coil has been started, using both hands, rotate the book (3) so that it is level to the table surface. While holding the book close to the binding edge so that the pages and holes stay aligned, set the coil on top of the Upper Roller (4). You will immediately notice the biggest advantage to Left Handed Coiling; Left Handed Coiling you can observe and dynamically control the insertion of the coil as it dives into the holes of the book (5) and immediately correct for miss alignment. Only the larger coil will use the Lower Roller in the upper position (6) as a rear guide.

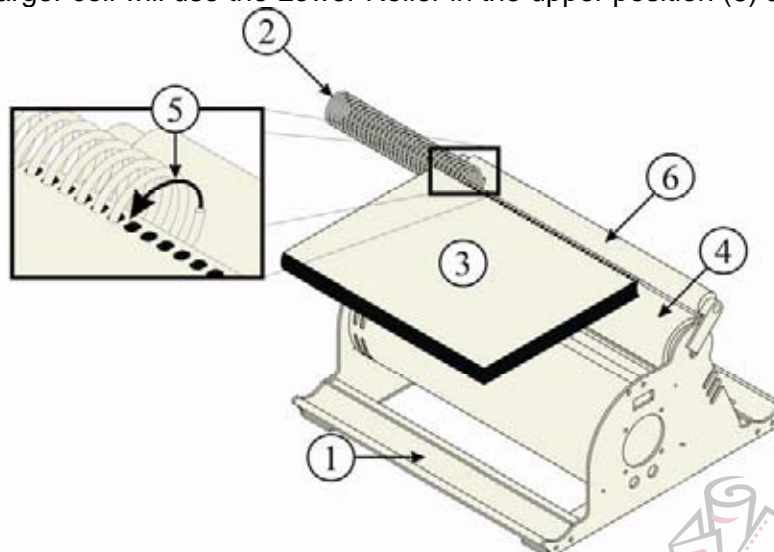
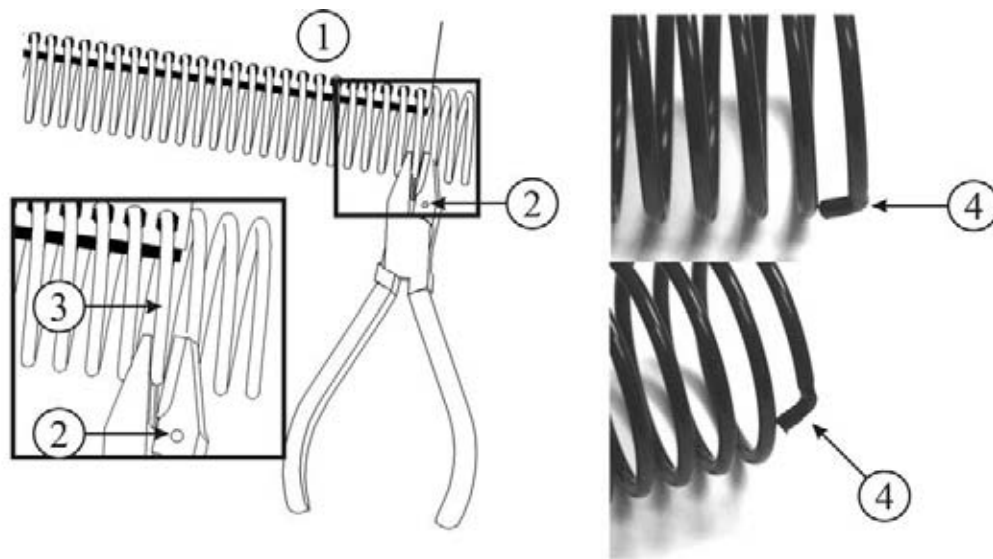

Fig. D

**4.4) Crimping.** See Fig. E. Once you have coiled your book crimping is made easy with the crimping pliers provided. Orient your book with the coiled side toward you (1) as shown, then on the right end of the book (1), orient the pliers with the dot (2) facing up. Open the pliers and grasp them around the first coil that exits the book (3). While keeping the pliers level with the book, snip the coil through. The pliers will finish the coil with an “L” shaped end (4) facing the book. This helps keep the coil from backing out of the book. Now you can flip the book over, keeping the coils toward you and repeat this same crimping technique to complete the book. Or you can keep the book stationary and flip the pliers over, move to the opposite end of the book and crimp the last coil that exits the book to complete the book. Contact your dealer for Crimping Pliers.



#### **5) Cleaning the HD-e4100 Econ-O-Tuff Coiler;**

Caring for your HD-E4100 Econ-O-Roll is important for the proper function of the machine. The finished tan and gray body should be cleaned with a very light water dampened cloth. The upper and lower rollers should be cleaned with a rubber cleaner and rejuvenator dampened cloth while the machine has been turned off and cooled.

#### **6) Product Registration;**

Product registration is important to establish trouble free warranty repair of any of your Rhin-O-Tuff equipment. Please fill out and mail in the card provided with your machine or register on-line at [www.RHIN-O-TUFF.com](http://www.RHIN-O-TUFF.com) .

### 7) Optional Binding Station Accessories;

Attachable to NEW EZ-Coil 4101 Book Former: The HD-4102 Docking Station Links the HD-e4100 Coil Inserter with the HD-4101 Book Former. Providing Controlled EZ-Coil Insertion with larger coil sizes up to 50MM. The HD-4104 Coil Chute Keeps the coil tangle free.

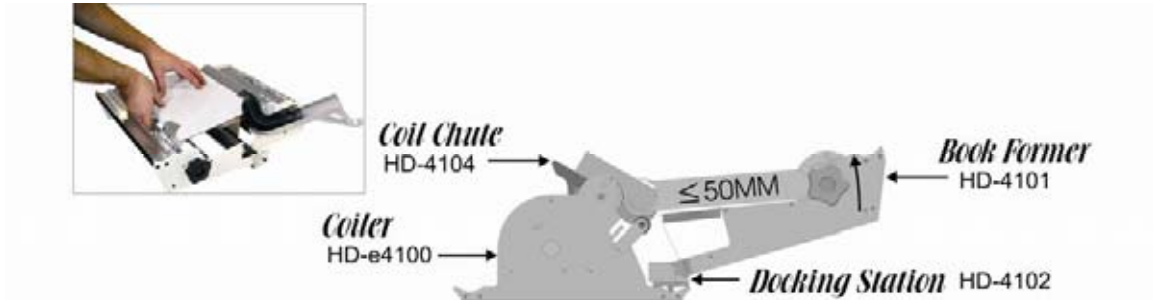



**THE ULTIMATE IN:**  
*Quality Punching & Binding Equipment*

Part #941005 12/06

# We Have it All...



## **MyBinding.com**

*When Image Matters.*

**Guaranteed Lowest Prices** on an  
Endless Selection of Binding Systems, Laminators,  
Paper Shredders, Supplies and Accessories.

**We have you covered** with Expert Advice  
and Support. Our popular blog keeps you up to  
date on the latest tips and techniques to make  
your most important binding and laminating  
tasks a success.

**Call Us Today**

**1-800-944-4573**

### **Our Trusted Partners**

GBC / Ibico  
Fellowes  
Powis Fastback  
Unibind  
Akiles  
Renz  
Tamerica  
Rhin-O-Tuff  
DFG

Pro-Bind  
Martin Yale  
MBM  
Formax  
Intimus  
Dahle  
HSM  
Standard  
Xyron

Challenge  
Lasko-Wizer  
GBC Shredmaster  
Avery  
Wilson Jones  
Cardinal  
Samsill  
Universal

- BINDING MACHINES
- BINDING SUPPLIES
- LAMINATORS
- I.D. ACCESSORIES
- BOARDS & EASELS
- PAPER SHREDDERS
- XYRON LAMINATORS
- COIL BINDING MACHINES
- UNIBIND BINDING MACHINES
- FASTBACK BINDING EQUIPMENT
- PAPER FOLDING MACHINES
- LAMINATING POUCHES
- ROTARY TRIMMERS
- CLEAR COVERS
- TWIN LOOP WIRE
- REGENCY COVERS
- PLASTIC BINDING COVERS
- VELOBIND BINDING MACHINES
- PAPER HANDLING EQUIPMENT
- THERMAL BINDING MACHINES
- PROCLICK BINDING SYSTEMS
- COMB BINDING MACHINES
- COMB BINDING SUPPLIES
- WIRE BINDING MACHINES
- POUCH LAMINATORS
- LAMINATING ROLLS
- 3-RING BINDERS
- ROLL LAMINATORS
- VELOBIND SPINES
- PAPER CUTTERS
- PAPER JOGGERS
- LETTER OPENERS
- THERMAL COVERS
- UNIBIND SUPPLIES
- PROCLICK SPINES
- ZIPBIND SPINES
- LINEN COVERS
- SPIRAL COIL
- INDEX TABS

