

RhinoTuff CI-3000 Coil Inserter

Setup & Operation Manual



Provided By

MyBinding.com
When Image Matters.

CI 3000 Coil Inserter

Setup & Operator Manual

Issue 1 April 02
Performance Design Inc.

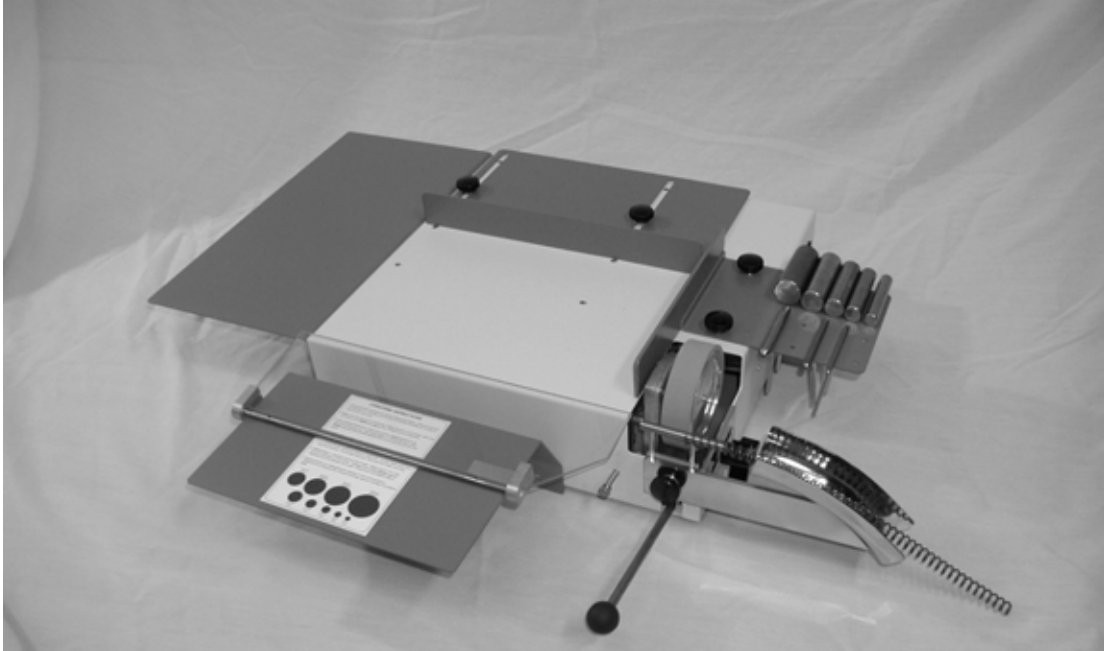

The CI 3000 plastic spiral inserter will bind books up to 1-1/8" (28.6mm) thick using coil diameters from 3/16" (5mm) up to 1-1/4" (30mm). Any pitch coil can be inserted with this machine.

Table of contents

Topic:	Page Number
1) Installation Instructions.	2
2) Determine the correct coil size.	3
3) Determine the correct size mandrel.	3
4) Installing the mandrel on the machine.	4
5) Adjusting the mandrel bracket.	4
6) Adjusting the book guides.	5
7) Adjusting the front table / coil guide.	5
8) Forward / off / reverse switch.	6
9) Inserting a coil.	6
10) Drive wheel stop screw.	7
11) Cutting a coil.	8
12) Troubleshooting	9

1) Installation Instructions: Diagram 1 & 2

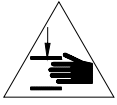

Keep all clothing and jewelry away from rotating drive wheel.

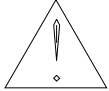

Power cord shall be certified for the country where the machine will be installed!

- ◆ Place the CI 3000 on a sturdy table at a good working height.
- ◆ Use two knobs and washers for each guide and table installed.
- ◆ Place the **right side book guide (spare mandrel holder) (1)** next to the drive wheel.
- ◆ When setting the **rear book guide (2)** in place, use the set of mounting holes that allow the edge of the book to hang over the edge of machine. (See adjusting book guide section)
- ◆ The **left side extension table (3)** will only need to be attached when binding long books. The added support of the table will help the binding process.
- ◆ Attach the **book table / coil guide (4)** to the front of the CI 3000.

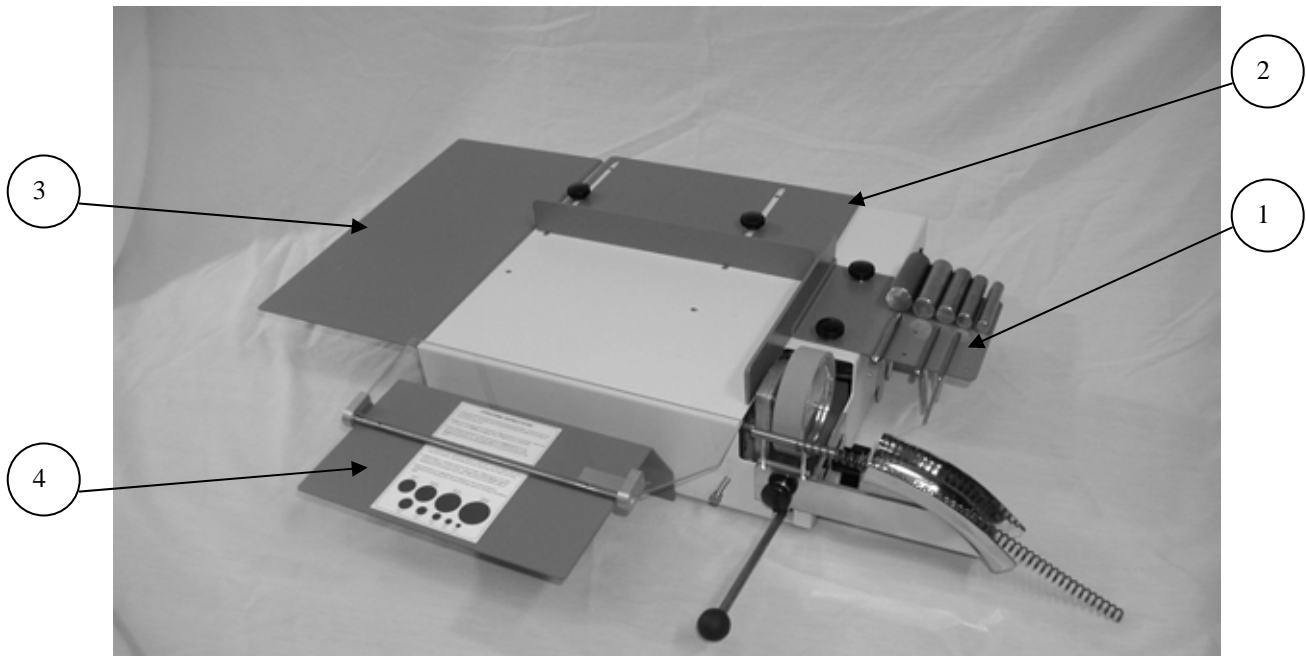

Diagram 1

- ◆ Place **stop screw & spring (5)** into front of CI 3000.
- ◆ Use the large winged knob and washer to install the **coil chute / mandrel holder (6)** to side of CI 3000.
- ◆ Thread **Motor handle (7)** into motor mount.
- ◆ Plug one end of the power cord into the back of the CI 3000 and the other end into the wall outlet.

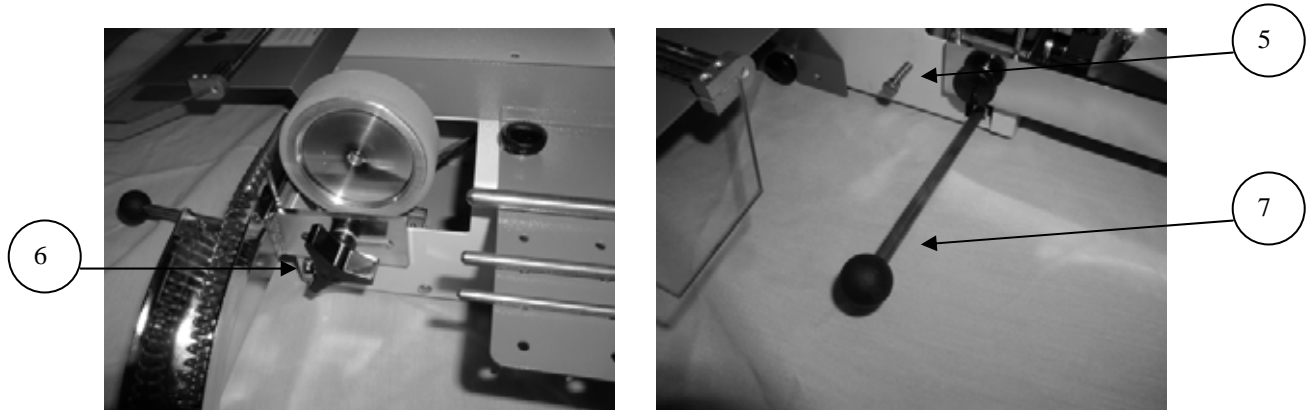

Diagram 2

2) Determine the correct coil size.

Use a coil that is at least 3/32" (2.5mm) larger than the book thickness for coil sizes up to 3/4" (20mm). After 3/4", use a coil size of at least 1/8" over the book size. The larger the coil compared to the book, inserting will become much easier.

3) Determine the correct size mandrel.

There are a total of nine mandrels, which are used for coil sizes 3/16" (5mm) up to 1-1/4" (30mm). Use the table below, to choose the correct mandrel size to coil size.

Mandrel size	Inch	Coil size	mm
3/16"	3-16" to 1/4"	(5mm-6mm)	
1/4"	5/16"	(7mm-8mm)	
5/16"	3/8"	(9mm-10mm)	
3/8"	7/16" to 1/2"	(11mm-12mm)	
1/2"	9/16"	(13mm-16mm)	
5/8"	3/4"	(17mm-19mm)	
3/4"	7/8"	(20mm-23mm)	
7/8"	1"	(24mm-27mm)	
1"	1-1/8" to 1-1/4"	(28mm-30mm)	

4) Installing the mandrel on the machine. Diagram 3

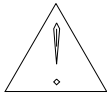

Keep all clothing and jewelry away from drive wheel during coil insertion!

- ◆ Place the **mandrel (8)** into the **mandrel holder bracket (9)** making sure the beveled edge of the mandrel is facing the right side of the machine. Both guide posts located on the mandrel need to line up with both slots on the mandrel bracket. Use the **black knob (10)** to tighten the mandrel in place.
- ◆ Adjust the height of the mandrel so the center of the mandrel is the same height as the center of the book.

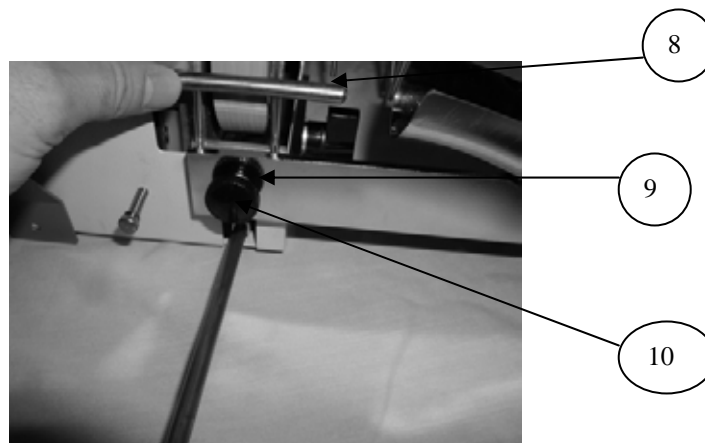

Diagram 3

5) Adjusting the mandrel bracket. Diagram 4

- ◆ The **coil chute / mandrel holder adjustment knob (11)** is located on the right side of the CI 3000. Move the assembly toward the drive wheel for small mandrels and away from the drive wheel for the larger mandrels.

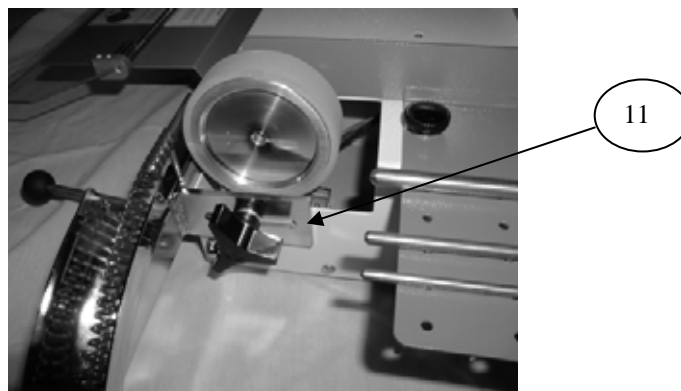

Diagram 4

6) Adjusting the book guides. Diagram 5

The **right side book guide (12)** can be adjusted slightly to the left or the right so the leading edge of the coil lines up with the first hole of the book.

Place the book on top of the CI 3000 with the right side of the book against the right side book guide. Adjust the **rear book guide (13)** so the holes of the book hang over the edge of the CI 3000. **The holes should hang over the edge just enough for the coil to clear the edge of the machine.** Tighten all four knobs at this time. It may be necessary to fine-tune this after a few books are bound for exact placement.

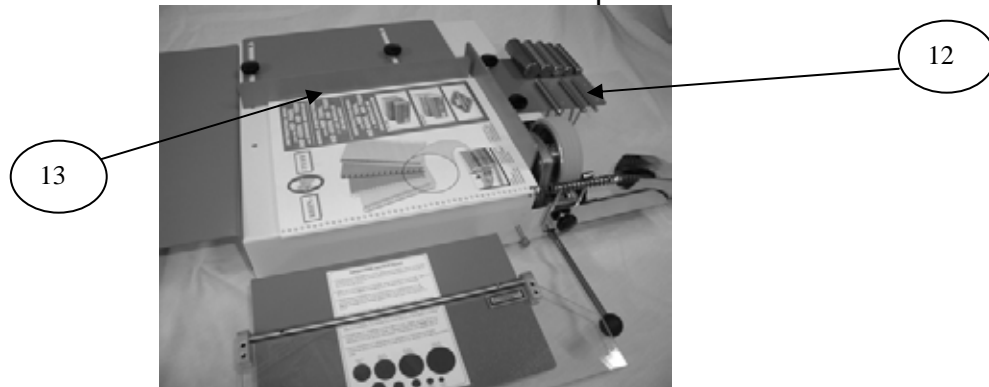

Diagram 5

7) Adjusting the front table / coil guide. Diagram 6

The **front table/ coil guide (14)** has two purposes. When the coil guide is rotated on top of the coil, it helps assist the coil into the book. Use the coil guide with all book sizes (thickness) until you notice a problem with the coil slipping on the drive wheel or entering the holes in the book. When the coil guide is in the open position, **rotated away from the machine**, it acts as a **support table (15)** for larger books. For books over 9/16", it may be necessary at times to split the book in half using the table to support one half of the book, then finish the inserting of the coil. This method improves productivity.

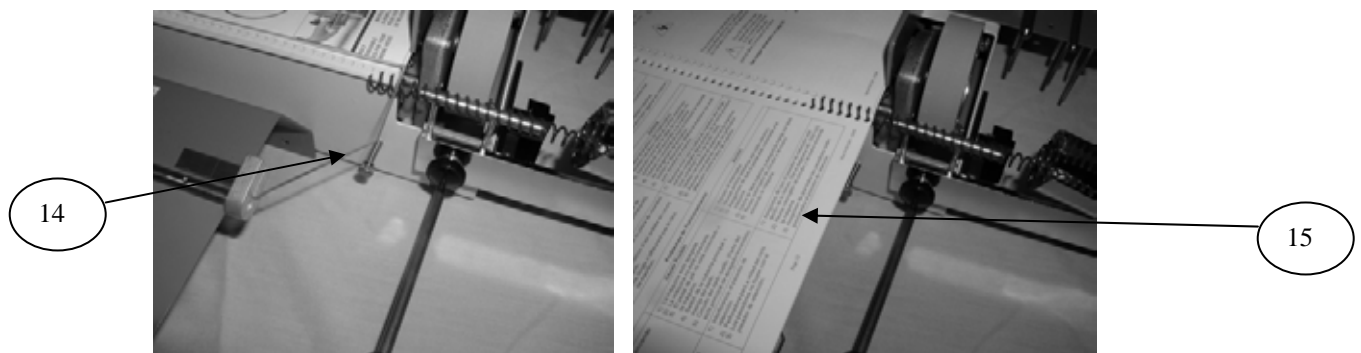

Diagram 6

8) Forward / off / reverse switch. Diagram 7

The **forward / off / reverse (16)** switch has three positions. The center position of this switch is the off position and should be placed in this position when not using the machine. Press the front (forward) of the switch and the coil will rotate into the book. Press the back (reverse) of the switch and the coil will exit the book. The reverse feature allows the coil to be removed from the book. Sometimes this will be necessary when the leading edge of the coil misses a hole of a single sheet.

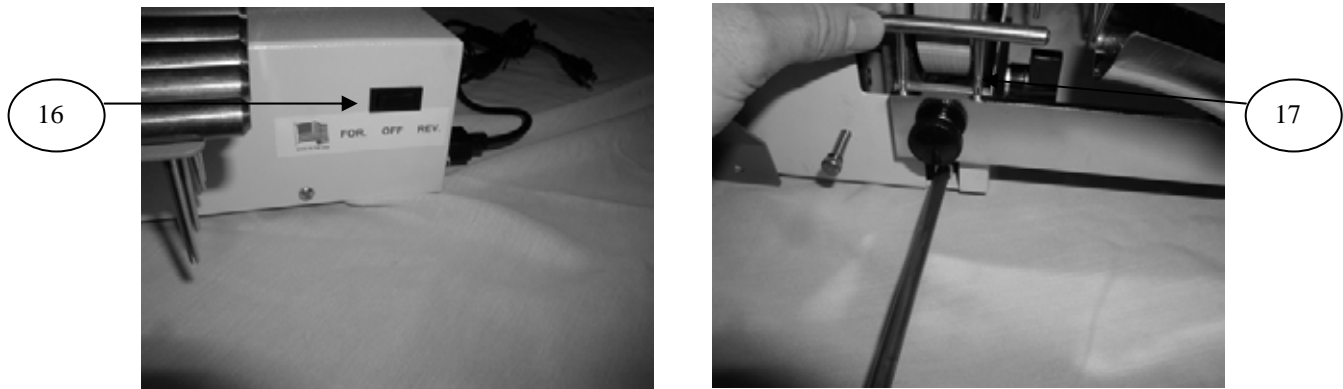

Diagram 7

9) Inserting a coil. Diagram 7 & 8

Place the coil on the mandrel by sliding the open end of the coil onto the beveled end of the mandrel. Turn the coil so it threads onto **the mandrel post (17)** and is in front of the drive wheel by one coil. Make sure the forward / reverse switch is in the forward position. Pull the **motor handle (18)** down to start the motor and engage the **drive wheel (19)** to the coil. Rotate the coil so it comes close to the edge of the book, but not past the book. With your right hand, hold the leading edge of the coil and thread it through the first two holes of the book. This helps align the holes of the book. Rotate the coil guide on top of the coil. Pull the handle down gently at first making sure the coil is rotating into the book without missing holes in the sheets or covers. Continue until the coil is past the left side of the book by about one or two coils.

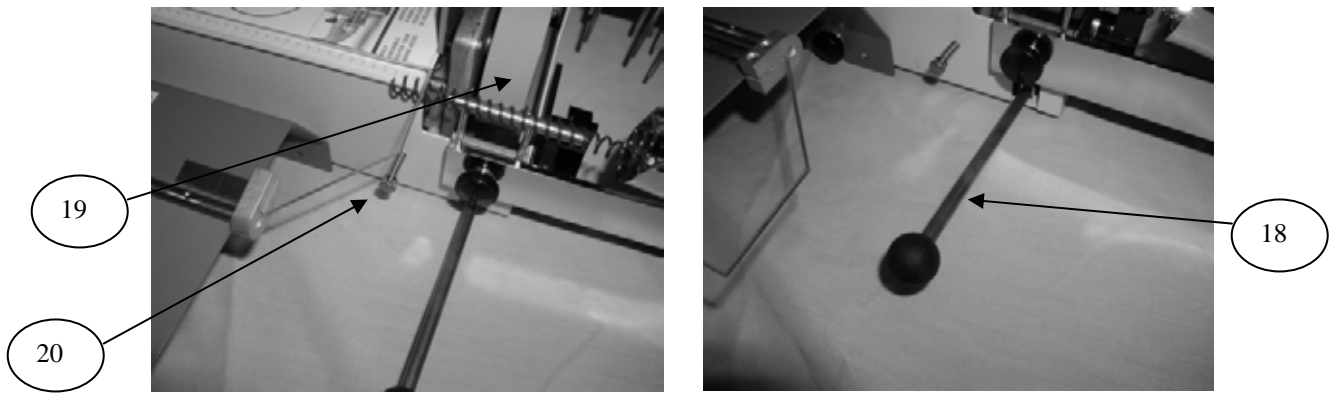

Diagram 8

10) Drive wheel stop screw. Diagram 8

The **drive wheel stop screw (20)** will prevent the wheel from pressing too hard on the mandrel. It is very important not to have too much pressure on the mandrel when inserting the larger coils. If the leading edge of the coil stops on a misaligned sheet, the coil wants to tie itself into a knot between the book and the end of the mandrel. Setting the stop screw will prevent this from happening most of the time. To set the stop screw, turn it clockwise to push the wheel away from the mandrel. Load the coil onto the mandrel and turn the stop screw counter clockwise while holding down on the motor handle until the drive wheel touches the coil. Try a few books and readjust if necessary.

If the coil chute / mandrel holder is moved after the stop screw has been adjusted, it will be necessary to readjust the stop screw.

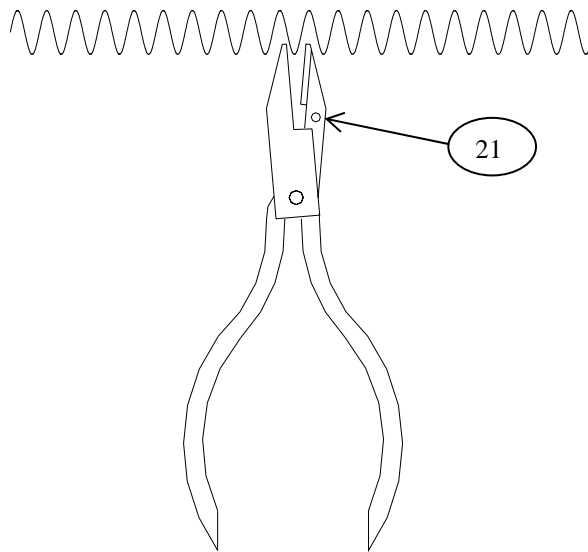

Diagram 9

11) Cutting a coil. Diagram 9 & 10

There are, special cutter crimper pliers (ordered separately) that are used to terminate the ends of the coil. After the coil is cut, the sharp end of the coil will tuck itself under the inside of the coil opening. To use the cutter, make sure the **red dot (21)** is facing up. Place the cutter on the edge of the right hand side of the book. Open the cutter enough so that the end of the cutter enters the coil by about a 1/4". **Make sure the cutter is level with the book before you cut.** As you squeeze the cutter you may notice the coil wants to twist. You can support the coil with your fingers as you cut to help stabilize the coil. Turn the book over and repeat these steps on the opposite end of the book. Always make sure to close crimping cutters completely.



Diagram 10

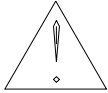

Only qualified personnel should attempt to work on this equipment.

Most of the problems you may encounter are due to setup errors. There is one fuse located at the rear of the CI 3000 inserter that can be replaced by the customer. Below is a troubleshooting guide to help you through most of the problems that may be encountered.

Troubleshooting

Symptom	Possible Cause	Action
Drive wheel does not rotate. (There is a thermal overload built inside of the motor. Wait several minutes before checking the fuse)	<ol style="list-style-type: none"> 1) Machine is off. (Switch is in center position) 2) Machine not plugged in. 3) Blown Fuse. 	<ol style="list-style-type: none"> 1) Place switch in either Forward or Reverse position. 2) Check both ends of power cord. 3) Check Fuse 1. (5amp)
Coil tightens on the mandrel when inserting.	<ol style="list-style-type: none"> 1) Mandrel is too large for coil. 	<ol style="list-style-type: none"> 1) Select proper size mandrel. (See page 3)
Coil stops before it is completely through the book.	<ol style="list-style-type: none"> 1) The holes in the book are misaligned. 2) The coil is beyond drive wheel. 	<ol style="list-style-type: none"> 1) This is normal. Try moving the book around so the coil rotates in the holes. 2) Coil length may need to be longer for that particular book. Note: Larger coils can wind themselves open so the length is actually less.

CI 3000 Electrical Schematic NOTE: The motor is protected by a thermal overload located in the motor. It will reset automatically after the motor cools.

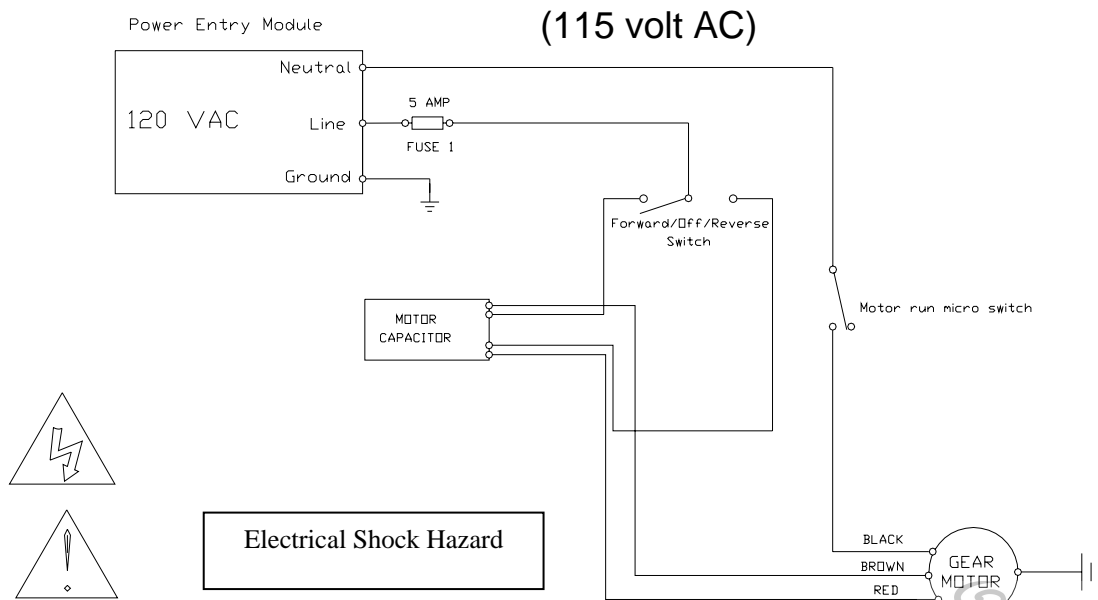

We Have it All...



MyBinding.com

When Image Matters.

Guaranteed Lowest Prices on an Endless Selection of Binding Systems, Laminators, Paper Shredders, Supplies and Accessories.

We have you covered with Expert Advice and Support. Our popular blog keeps you up to date on the latest tips and techniques to make your most important binding and laminating tasks a success.

Call Us Today

1-800-944-4573

Our Trusted Partners

GBC / Ibico

Fellowes

Powis Fastback

Unibind

Akiles

Renz

Tamerica

Rhin-O-Tuff

DFG

Pro-Bind

Martin Yale

MBM

Formax

Intimus

Dahle

HSM

Standard

Xyron

Challenge

Lasko-Wizer

GBC Shredmaster

Avery

Wilson Jones

Cardinal

Samsill

Universal

BINDING MACHINES
BINDING SUPPLIES
LAMINATORS
I.D. ACCESSORIES
BOARDS & EASELS
PAPER SHREDDERS
XYRON LAMINATORS
COIL BINDING MACHINES
UNIBIND BINDING MACHINES
FASTBACK BINDING EQUIPMENT
PAPER FOLDING MACHINES
LAMINATING POUCHES
ROTARY TRIMMERS
CLEAR COVERS
TWIN LOOP WIRE
REGENCY COVERS
PLASTIC BINDING COVERS
VELOBIND BINDING MACHINES
PAPER HANDLING EQUIPMENT
THERMAL BINDING MACHINES
PROCLICK BINDING SYSTEMS
COMB BINDING MACHINES
COMB BINDING SUPPLIES
WIRE BINDING MACHINES
POUCH LAMINATORS
LAMINATING ROLLS
3-RING BINDERS
ROLL LAMINATORS
VELOBIND SPINES
PAPER CUTTERS
PAPER JOGGERS
LETTER OPENERS
THERMAL COVERS
UNIBIND SUPPLIES
PROCLICK SPINES
ZIPBIND SPINES
LINEN COVERS
SPIRAL COIL
INDEX TABS

