

Martin Yale 7000E Guillotine Cutter

Blade Leveling Guide



Provided By

MyBinding.com®
When Image Matters.



Blade Removal, Installation and Leveling for the 7000E

Disclaimer

The following instructions are intended for a qualified field technician. Martin Yale Industries does not recommend that non-qualified personnel perform this procedure. Martin Yale Industries assumes no responsibility for any accident or injury received while attempting to repair the 7000E. For service referrals call 800-225-5644. Customer Service will be glad to assist in locating a service dealer in your area.

Even a dull blade is a very dangerous item. Exercise caution in handling the blade. This procedure should be performed in an area free from traffic. Protective gloves are recommended while handling the blade. Read all instructions before proceeding.

Tools Needed

7/64" Allen Wrench
9/64" Allen Wrench
Phillips Screwdriver
Pliers or Adjustable Wrench

Blade Removal

1. Remove the trim from the top of the blade/clamp assembly. To do this remove Phillips head screw adjacent to the clamp wheel (Step 1), lower clamp to the 'down' position, and slide the trim towards the clamp wheel. This will allow a lip on the bottom of the trim to disengage from the spacer bar in step 2.
2. Using 7/64" Allen, remove spacer from between the frame.
3. Using 9/64" Allen, remove two screws going through the safety plate. Set screws and plate to side.



STEP 1



STEP 2



STEP 3

4. Once removed, the handle and knife assembly can be lifted from between the frame. **DO NOT LIFT THE BLADE OUT OF THE UNIT UNTIL READING FURTHER.** Once lifted out you'll see a pin in the handle that goes through a hole in the blade (circled below, Step 4). The entire assembly is held together by the pin only. What's needed at this point is to separate the handle assembly from the blade and put to side. Something will be needed to hold the blade in the air once this is done, to prevent the blade from crashing back down into the frame (Step 4-1). A screwdriver is ideal for this, and also provides a handle for sure grip. Remember, the blade is precise and the edge is easy to damage. Careful attention must be given to prevent the blade from being chipped in the process of removal and reinstallation.

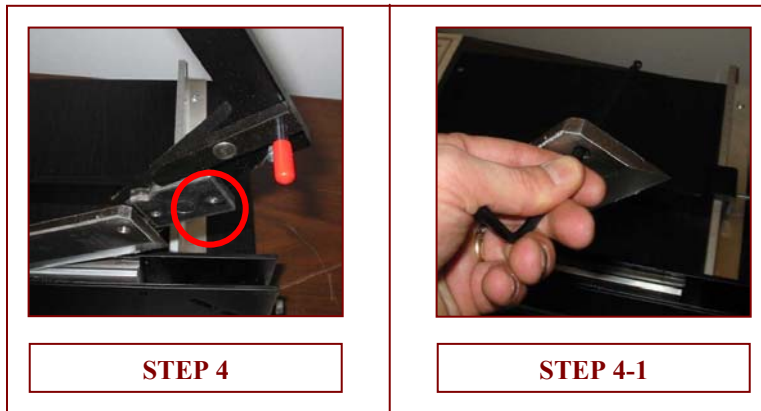

Once the handle has been removed and set to the side, and something has been inserted into the hole of the blade to hold it in place, you can unthread the blade. What must be understood in removing the blade is the side of the blade still inside the unit must be removed from the same side you are holding the blade up from (See 4-2). This is due to a set of roller guides (#24 in Parts Schematic, 4-3 Below) that control the movement of the blade. In order to dislodge, the blade will have to be lifted to an approx. 70° angle (See Parts Schematic for phantom shot), which will cause the blade cam roller and pin to go out of the bottom of the guides.

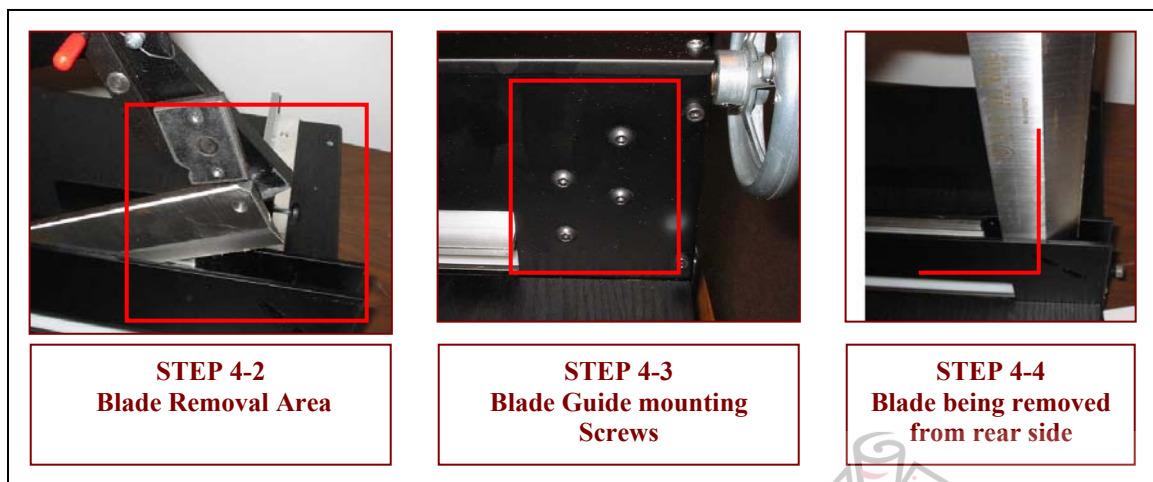

5. Once achieved, slide the blade to the rear of the unit, where it can be lifted from the frame. Place the blade on a flat surface free from traffic. Be careful to not lose the cam roller.
6. Sharpening of the blade must be done in a precise fashion: a 19-degree angle with a surface grinder. Any change in the blade edge angle bevel could cause the unit to malfunction. Depending on the severity of the error, the blade may have to be replaced or re-sharpened.
7. In order to reinstall the blade, the above listed steps need to be reversed. Don't forget to re-install the cam roller.

Once reinstalled, it's necessary to level the blade and rotate the cutting stick.
NOTE: Because of different servicing situations, it has not been assumed that the blade was removed prior to this procedure.

1. LOOSEN the two Allen head screws that go through the safety plate (1-1). Loosen locking nut on blade adjustment bolt and back out of hole (1-2). It is not necessary to completely remove the bolt.



Figure 1-1

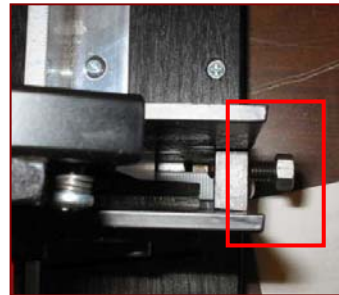
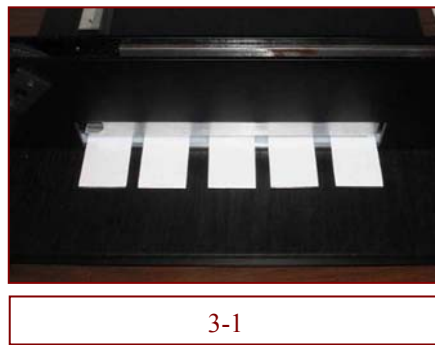
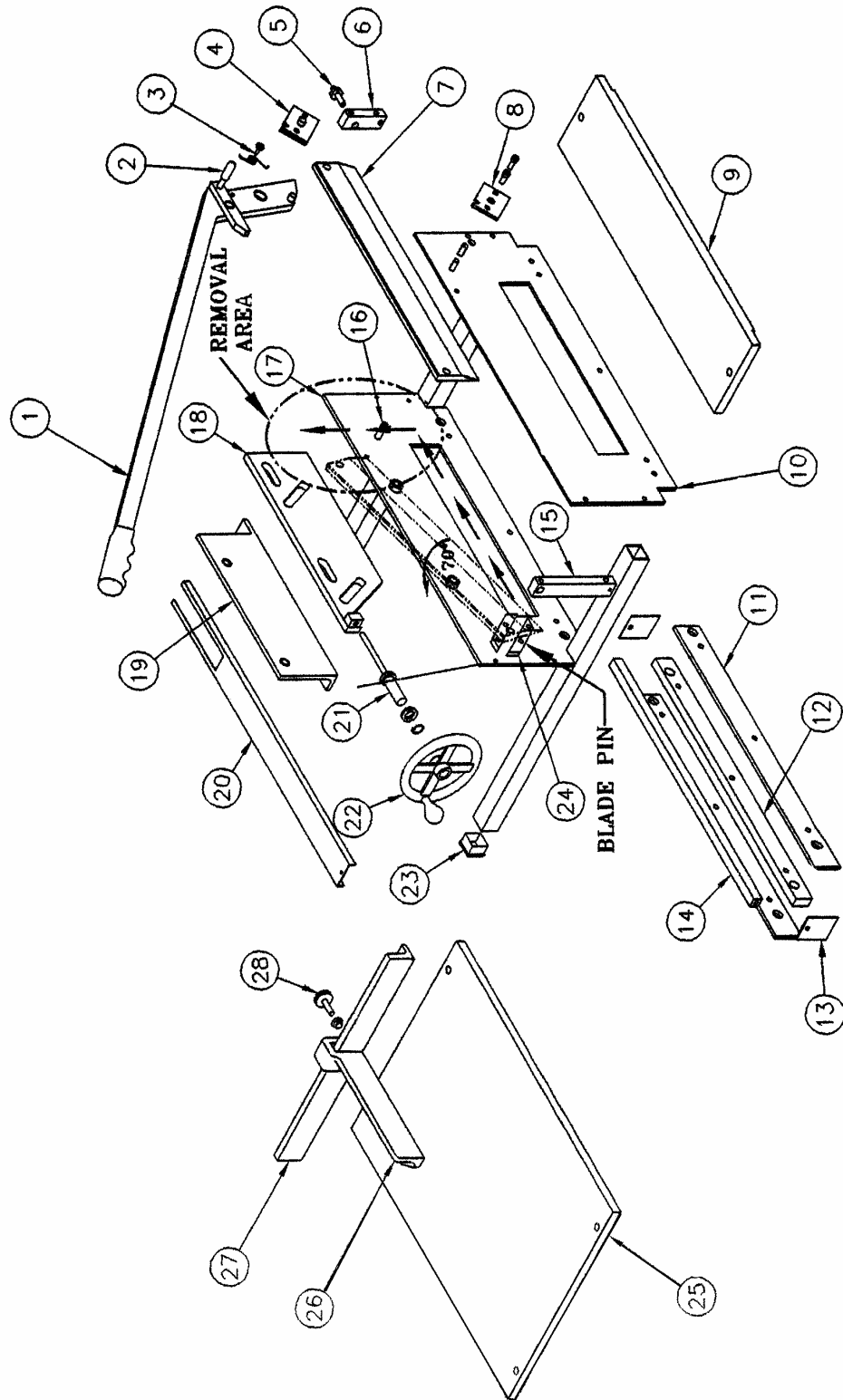

Figure 1-2

2. Once loosened blade will become free moving, going up and down as you manipulate handle, but without side to side consistency. Cycle the handle twice to insure that blade is in a natural position.
3. Tear five (5) approximately 1" wide strips from a sheet of 20# Bond stock. Fold strips in half. Equally space the (5) strips across the cutting stick, making sure that you have one at each end and the other three equally spaced in between. Do not clamp. (Figure 3-1)



4. With strips in place, begin slowly bringing the blade down until there is good pressure on strip 1 (3-2). This is determined by attempting to pull on strip and feeling for resistance. Once it is determined that there is pressure on strip 1, move to strip 2 while holding the handle steady. Resume slowly lowering blade until similar pressure is placed on strip 2. Once strip 2 has pressure applied, move to strip 3 and repeat. Continue with each strip until you have come to strip 5. **When strip 5 has pressure, STOP! Otherwise the opposite end of blade (strip 1) will begin to raise up. When it is verified that strips 1 and 5 have pressure on them, tighten the 2 Allen screws in the safety plate.**
5. Once the screws have been tightened, raise the handle until the safety latch engages. Remove the metal end caps from the cutting stick (#13 and #14 in Parts Schematic) and rotate to a new side.
6. Place one sheet of paper on the cutting stick and make a cut. It may be necessary to use excessive pressure the first time, to place a groove into the stick.
7. Once the cut has been made, leave the handle in the 'down' position. Adjust the blade depth bolt to the point that it is making contact with the end of the handle and tighten nut. This is to prevent premature gouging of the cutting stick.



We Have it All...



MyBinding.com *When Image Matters.*

Guaranteed Lowest Prices on an
Endless Selection of Binding Systems, Laminators,
Paper Shredders, Supplies and Accessories.

We have you covered with Expert Advice
and Support. Our popular blog keeps you up to
date on the latest tips and techniques to make
your most important binding and laminating
tasks a success.

Call Us Today

1-800-944-4573

Our Trusted Partners

GBC / Ibico
Fellowes
Powis Fastback
Unibind
Akiles
Renz
Tamerica
Rhin-O-Tuff
DFG

Pro-Bind
Martin Yale
MBM
Formax
Intimus
Dahle
HSM
Standard
Xyron

Challenge
Lasko-Wizer
GBC Shredmaster
Avery
Wilson Jones
Cardinal
Samsill
Universal



- BINDING MACHINES
- BINDING SUPPLIES
- LAMINATORS
- I.D. ACCESSORIES
- BOARDS & EASELS
- PAPER SHREDDERS
- XYRON LAMINATORS
- COIL BINDING MACHINES
- UNIBIND BINDING MACHINES
- FASTBACK BINDING EQUIPMENT
- PAPER FOLDING MACHINES
- LAMINATING POUCHES
- ROTARY TRIMMERS
- CLEAR COVERS
- TWIN LOOP WIRE
- REGENCY COVERS
- PLASTIC BINDING COVERS
- VELOBIND BINDING MACHINES
- PAPER HANDLING EQUIPMENT
- THERMAL BINDING MACHINES
- PROCLICK BINDING SYSTEMS
- COMB BINDING MACHINES
- COMB BINDING SUPPLIES
- WIRE BINDING MACHINES
- POUCH LAMINATORS
- LAMINATING ROLLS
- 3-RING BINDERS
- ROLL LAMINATORS
- VELOBIND SPINES
- PAPER CUTTERS
- PAPER JOGGERS
- LETTER OPENERS
- THERMAL COVERS
- UNIBIND SUPPLIES
- PROCLICK SPINES
- ZIPBIND SPINES
- LINEN COVERS
- SPIRAL COIL
- INDEX TABS