

# MBM Bookletmaker Jr.

## Instruction Manual



Provided By

**MyBinding**.com®  
*When Image Matters.*

# Operation Manual

## FOR BOOKLETMAKER Jr.

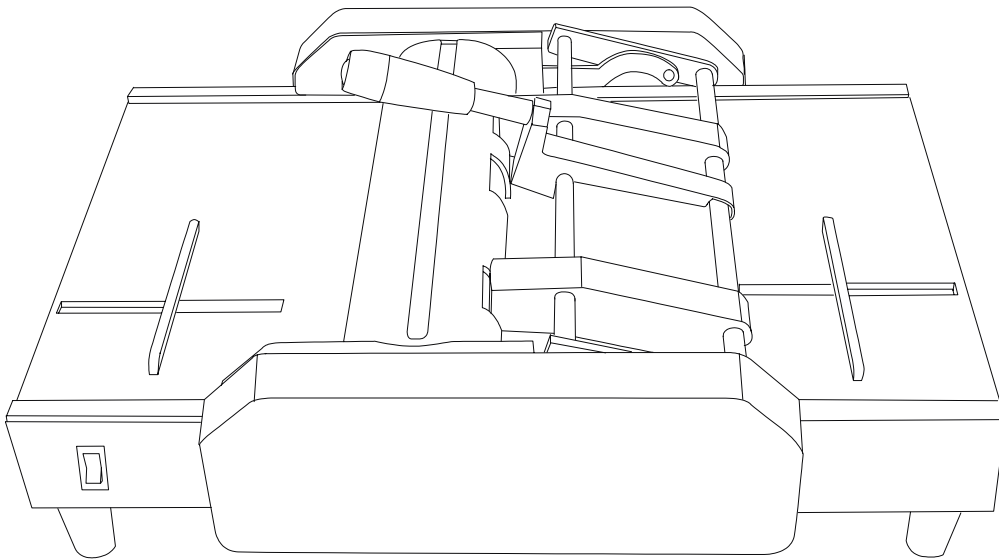

**MBM**  
CORPORATION

1-800-223-2508  
[www.mbmcorp.com](http://www.mbmcorp.com)

Keep this manual so that it can be retrieved whenever needed



## **CAUTION**

When the machine is running, never put your hands near or under the rollers.

Do not remove the bottom lid, front and rear covers from the machine. The inside of the machine contains high voltage parts or hazardous moving parts, which may cause electric shock or personal injury.

A socket-outlet shall be installed near the equipment and shall be easily accessible.

# Warning

---

Warning:  
hazardous moving parts keep hands  
and other body parts away.

Warn:  
The surface of the motor is hot.  
Be careful, Don't touch

# Caution

---

Caution:  
For continued protection  
against risk of fire, replace only with  
the same type and rating of fuse.

No.	Description	Qty
1	Warning Label 1	1
2	Cover Label	2
3	Brand Label	1
4	Model Label	1
5	Fuse Label	1
6	Caution Label	1
7	Warning Label 2	1
8	Warning Label 3	1

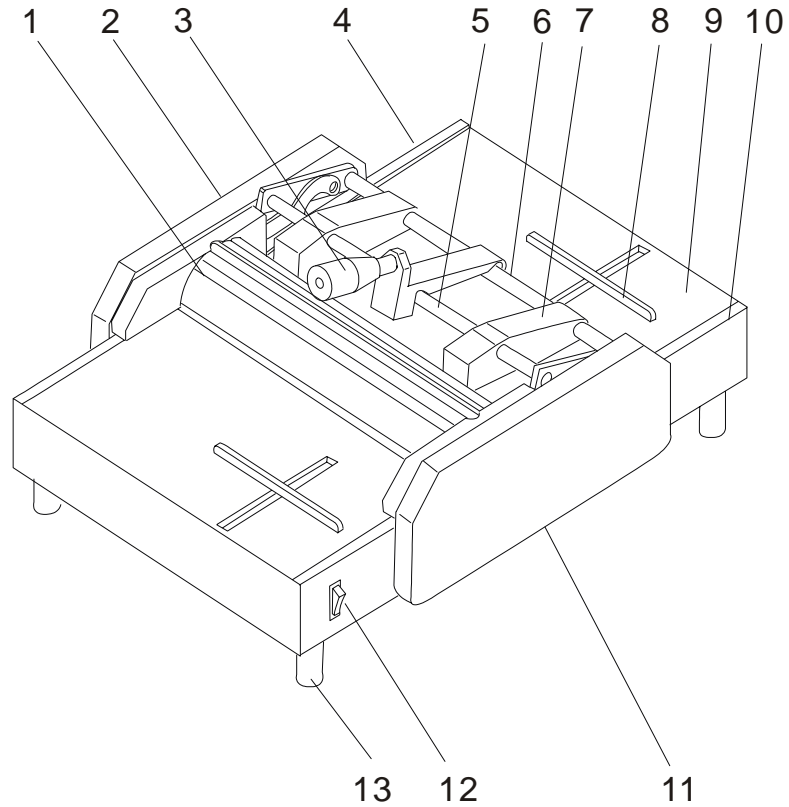

## Main Operating Parts

- |                        |                     |
|------------------------|---------------------|
| (1) Safety Cover       | (8) Paper Guide     |
| (2) Back Cover         | (9) Table           |
| (3) Stapling Handle    | (10) Side Guide (A) |
| (4) Side Guide (B)     | (11) Front Cover    |
| (5) Sub Holding Shaft  | (12) On/Off Switch  |
| (6) Main Holding Shaft | (13) Rubber Feet    |
| (7) Stapling Head      |                     |

1

⚠ Warning hazardous moving parts keep hands and other body parts away

2

Do not remove the cover  
Doing so may result in personal injury

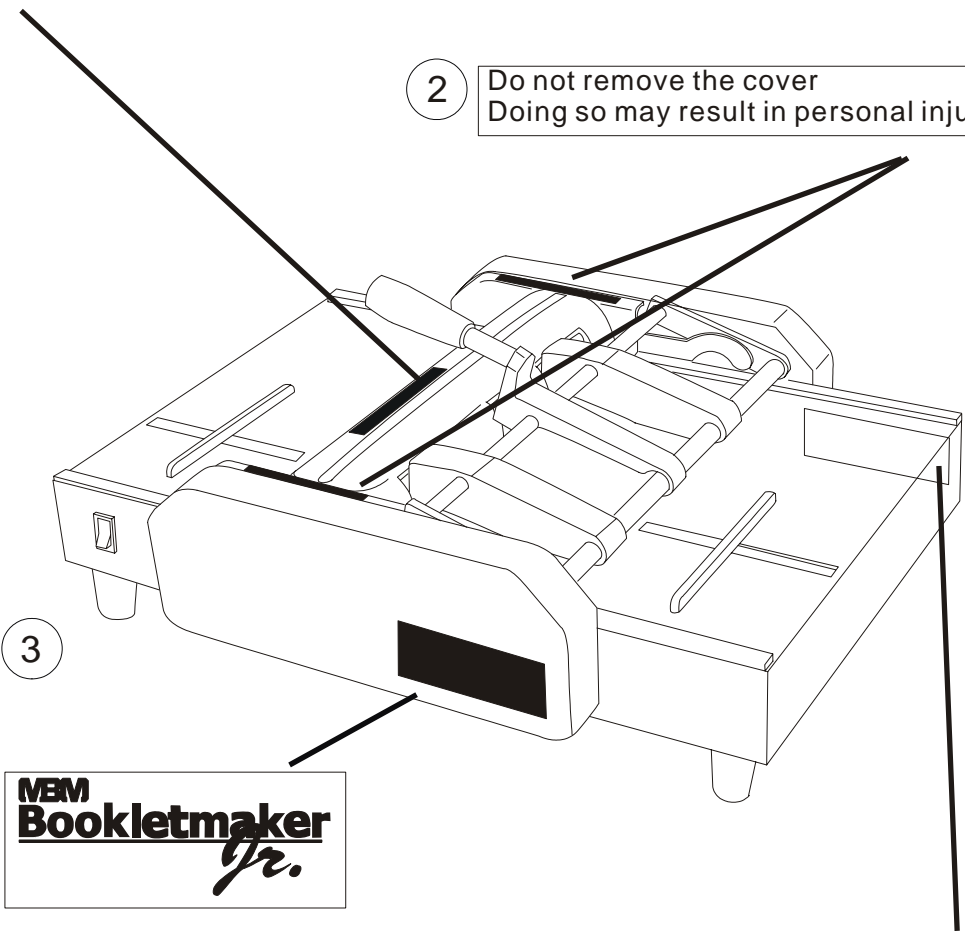

3

**VBM**  
**Bookletmaker**  
*Jr.*

4

<b>VBM</b> CORPORATION	MODEL
	BOOKLETMAKER Jr.
N. Charleston, SC 29418	800-223-2508
SERIAL NO: <input type="text"/>	
VOLTS: 110VAC	Hz: 60 AMP: 0.8

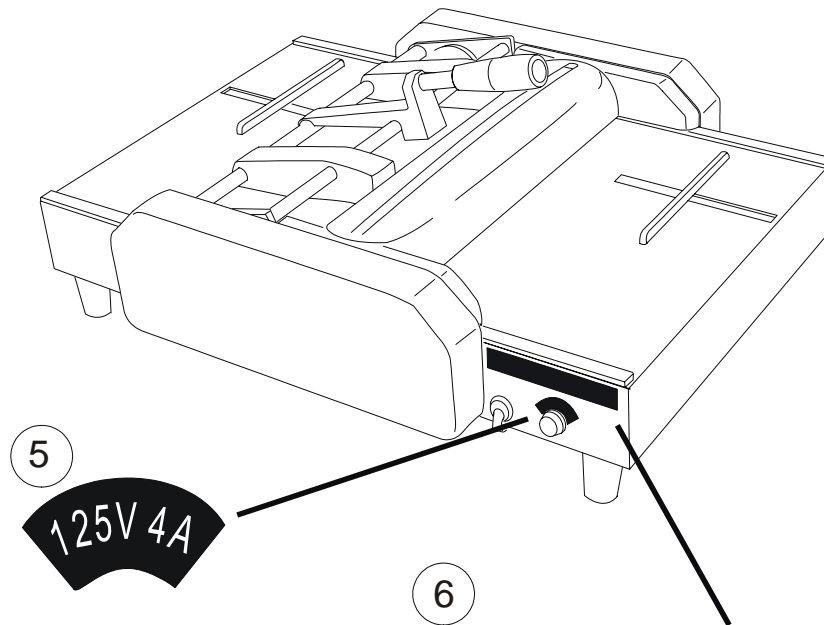

**⚠ CAUTION:**  
FOR CONTINUED PROTECTION AGAINST RISK OF FIRE, REPLACE ONLY WITH THE SAME TYPE AND RATING FUSE.

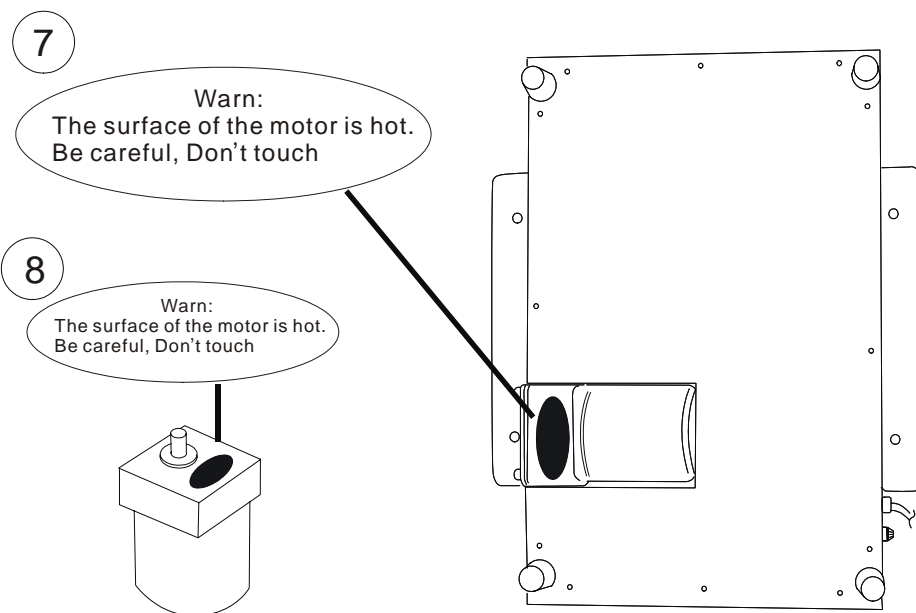

## Operation Procedures

### 1. Before Operating

- 1.1 Fit stapling handle: First insert the end of the stapling handle at the main holding shaft then press in the sub-holding shaft.
- 1.2 Load Staples
- 1.3 Connect the power cable

### 2. Make a Booklet

- 2.1 Switch on the machine
- 2.2 Choose the correct staple position according to the sheet size.
- 2.3 Set the paper guides; place the sheets under the rollers and align the sheets to side guide (A).
- 2.4 Set the paper guides to hold the sheets in position.
- 2.5 Press down the stapling handle to complete the stapling.
- 2.6 Lift up the stapling handle and firmly press down to the other side and hold. The stapled sheets will be fed up through the fold rollers to complete the booklet.
- 2.7 Repeat steps 2.3-2.6 for further booklets.
- 2.8 Switch off the machines after finishing.

### 3. Side Stapling

- 3.1 Choose and fix the staple position according to the sheet size.
- 3.2 Place the sheets under the rollers.
- 3.3 Depending on the stapling position, align the sheets to side guide (A) or side guide (B)
- 3.4 Set the side distance and hold the sheets.
- 3.5 Press down the stapling handle for stapling.
- 3.6 Repeat steps 3.2-3.5 for further side stapling.

### 4. Repair & Maintenance

- 4.1 Always clean up machine after used.

## Specifications

Paper size	Min.197mmx273mm (7.8" x 10.8") Max. 297mmx420mm ( 11.7" x 16.5")
Max. Stapling Amount	10 sheets of 70gsm Bond paper* (20 lbs. paper)
Max. Folding Amount	10 sheets of 70gsm Bond paper* [40 pages booklet] (20 lbs. paper)
Power source	AC 110V 0.8A 60Hz
Watt	40W
Dimensions	500mmx235mmx395mm (19.7" x 9.3" x 15.6")
Weight	15Kg (33lbs.)

\* This may vary depending upon paper quality

# We Have it All...



## **MyBinding.com**

*When Image Matters.*

**Guaranteed Lowest Prices** on an  
Endless Selection of Binding Systems, Laminators,  
Paper Shredders, Supplies and Accessories.

**We have you covered** with Expert Advice  
and Support. Our popular blog keeps you up to  
date on the latest tips and techniques to make  
your most important binding and laminating  
tasks a success.

**Call Us Today**

**1-800-944-4573**

### **Our Trusted Partners**

GBC / Ibico  
Fellowes  
Powis Fastback  
Unibind  
Akiles  
Renz  
Tamerica  
Rhin-O-Tuff  
DFG

Pro-Bind  
Martin Yale  
MBM  
Formax  
Intimus  
Dahle  
HSM  
Standard  
Xyron

Challenge  
Lasko-Wizer  
GBC Shredmaster  
Avery  
Wilson Jones  
Cardinal  
Samsill  
Universal

- BINDING MACHINES
- BINDING SUPPLIES
- LAMINATORS
- I.D. ACCESSORIES
- BOARDS & EASELS
- PAPER SHREDDERS
- XYRON LAMINATORS
- COIL BINDING MACHINES
- UNIBIND BINDING MACHINES
- FASTBACK BINDING EQUIPMENT
- PAPER FOLDING MACHINES
- LAMINATING POUCHES
- ROTARY TRIMMERS
- CLEAR COVERS
- TWIN LOOP WIRE
- REGENCY COVERS
- PLASTIC BINDING COVERS
- VELOBIND BINDING MACHINES
- PAPER HANDLING EQUIPMENT
- THERMAL BINDING MACHINES
- PROCLICK BINDING SYSTEMS
- COMB BINDING MACHINES
- COMB BINDING SUPPLIES
- WIRE BINDING MACHINES
- POUCH LAMINATORS
- LAMINATING ROLLS
- 3-RING BINDERS
- ROLL LAMINATORS
- VELOBIND SPINES
- PAPER CUTTERS
- PAPER JOGGERS
- LETTER OPENERS
- THERMAL COVERS
- UNIBIND SUPPLIES
- PROCLICK SPINES
- ZIPBIND SPINES
- LINEN COVERS
- SPIRAL COIL
- INDEX TABS

