

# MBM 307A / 407A PF Automatic Folders

## Instruction Manual



Provided By

**MyBinding**.com®  
*When Image Matters.*

# OPERATION MANUAL

MBM 307A / 407A

AUTOMATIC FOLDERS



**MBM**  
CORPORATION

1-800-223-2508  
[www.mbmcorp.com](http://www.mbmcorp.com)





# Safety Instructions

## Definition of Symbols and Notes

The following names and signs stand for possible dangers.



### Danger

This symbol stands for immediate danger. Disregarding these instructions may cause severe injury.



### Caution

This symbol stands for a potentially dangerous situation. Disregarding these instructions may lead to injuries or damage to property.



### Note

This symbol stands for notes, operational hints and other useful information.

| <h2>Danger</h2>                                     |  |
|---|--|
|   | Make sure that the machine is electrically grounded to prevent electrical shock.   |
|   | Use the machine at 120 VAC with a frequency of 60Hz. There is a risk of electrical shock or fire if a higher or lower voltage is used, or if an electric current is utilized with a frequency not within the range stated above. |
|   | Do not place any object on top of this machine. There is a risk of electrical shock or fire if water or any foreign object enters the machine.   |
|   | Handle the power cord with care. There is a risk of electrical shock or fire if the cord is damaged, broken, or placed under a heavy object.   |
|   | Do not insert or remove the power plug when water is present.  |
|   | Do not remove the cover of this machine. There is a risk of an electrical shock.   |
|   | Do not reconfigure the electronics of this machine. There is a risk of an electrical shock or fire.  |
|   | Do not operate the machine if it is emitting smoke or a strange odor. Turn off the machine, unplug from the outlet and contact your dealer.  |
|   | Do not operate the machine if the power cord is generating heat or emits a strange smell. Turn off the machine, unplug from the outlet and contact your dealer.  |
|   | If a foreign object enters into the machine, turn off the power switch and remove the power plug, then consult your dealer.  |
| In the event of a thunderstorm, unplug the machine. |  |

| <h2>Caution</h2> |  |
|------------------|--|
|                  | Keep hair, clothing, and jewelry away from the machine while operating. Serious injury may result.   |
|                  | Do not put the machine on an unstable or slanted surface. Doing so may cause the machine to drop or fall, causing damage and possible injury.  |
|                  | Store and operate the machine in a clean, dust-free environment with low humidity. Avoid areas with high moisture, extreme temperatures and excessive dust, as these conditions may cause machine failure or electrical shock. |
|                  | Be sure to grasp the power cord by the plug when removing from the electrical outlet. Not doing so may cause damage to the cord and possible electrical shock or fire.   |
|                  | Be sure to pull the power plug out of the electric outlet before moving the machine. Not doing so may cause damage to the cord and possible electrical shock or fire.  |
|                  | Remove the power plug from the electrical outlet when this machine is not in use.  |

# Introduction

Thank you for purchasing the MBM 307A / 407A Automatic Paper Folder. You should receive many years of reliable service from this machine. Compact and easy to use, the 307A / 407A Paper Folder is sure to streamline your paper folding tasks, saving you valuable time. Please read the Operation Manual thoroughly before using this machine.

This Operation Manual is good for both 307A/407A .

Explanations of functions unique to the 307A are indicated in *italics*.

## Contents







|   |    |
|---|----|
| Safety Instructions .....   | 2  |
| Introduction.....   | 3  |
| Contents .....  | 3  |
| (1) Specifications .....  | 4  |
| (2) Accessories .....   | 5  |
| (3) Part Names .....  | 6  |
| (4) Designation and Functions of Operation Panel.....                   | 7  |
| (5) Operation of the Counter .....                                      | 8  |
| (A) Addition Counter .....  | 8  |
| (B) Subtraction Counter .....   | 8  |
| (6) Set -Up.....  | 9  |
| (7) Directions for Use .....  | 10 |
| (A) Standard Folding of Standard-size Paper .....                       | 10 |
| (B) Manual set up for Standard Folding of Non-Standard-size Paper ..... | 12 |
| (C) Cross Folding.....  | 14 |
| (8) Adjustments .....   | 15 |
| (A) Skew Adjustments .....  | 15 |
| (B) Fine Adjustments .....  | 15 |
| Fine Adjustments for Table 1 .....                                      | 16 |
| Fine Adjustments for Table 2 .....                                      | 17 |
| (9) Memory .....  | 18 |
| (A) Storage.....  | 18 |
| (B) Cancellation of Memory .....  | 19 |
| (C) Cancellation of Total Memory .....                                  | 19 |
| (10) Maintenance (Cleaning and replacement of consumable items).....    | 20 |
| (11) Troubleshooting .....  | 22 |
| (12) Removing the fold tables .....                                     | 23 |

(1) Specifications

|                       |   |
|-----------------------|---|
| Model:                | 307A / 407A   |
| Paper sizes:          | 3.5" x 5.0" to 11" x 17"<br>3.5" X 5.0" size is for SINGLE fold only.<br>5" x 7.2" size cannot be folded into GATE.   |
| Paper weight:         | 45 to 105g/m <sup>2</sup> (up to 152g/m <sup>2</sup> for single fold) 14 to 70 lb   |
| Paper quality:        | Medium and high-quality paper, high-quality paper for stencil printing.   |
| Fold types:           | Single, gate, letter, zigzag, double parallel, and fold-out. Irregular folding and cross folding using double fold.   |
| Fold dimensions:      | Maximum fold dimensions<br>Table 1: 12.6" (zigzag, double parallel, and fold-out)<br>Table 2: 8.5" (single, gate, and letter)   |
|                       | Minimum fold dimensions<br>Table 1: 2.0" (gate and letter)<br>Table 2: 1.6" (single, zigzag, double parallel, and fold-out)   |
| Paper feed system:    | Three-roller friction feed system   |
| Maximum capacity:     | 500 sheets (20 lb bond)   |
| Folding speed:        | 3700 to 11520 sheets per hour (single fold using letter size paper)   |
| Control system:       | Automatic setting by built-in microcomputer   |
| Additional functions: | Skew correction device<br>Paper jam detector<br>Four-digit counter with addition/subtraction modes<br>Automatic paper size detector (letter, legal & ledger sizes)<br>Memory function : 6 kinds<br>Auxiliary paper guide for cross fold<br>Perforating Option |
| Noise                 | 80dB  |
| Power consumption:    | 75W, 0.7A   |
| Power source:         | 120 VAC/60Hz  |
| Dimensions:           | 34.25" x 20.9" x 20.5" (during use)<br>26" x 20.9" x 20.5" (during storage)   |
| Net weight:           | 74 lb      Shipping Weight: 86 lb   |
| Options:              | Perforator table assembly with a 2 mm or 4 mm perforation cutter<br>Scoring table assembly<br>Manual feed tray  |

## (2) Accessories

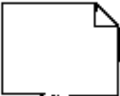
After un-boxing the 207M, make sure that the following accessories are present. Please contact your local dealer immediately if anything is missing.

| Accessories                                    | Number            |   |
|--|-------------------|---|
| Table 1  | 1                 |     |
| Table 2  | 1                 |     |
| Power cord                                     | 1                 |   |
| Auxiliary paper feed guide<br>(right and left) | Right 1<br>Left 1 |   |
| Machine cover                                  | 1                 |  |
| Operation Manual                               | 1                 |  |

### (3) Part Names

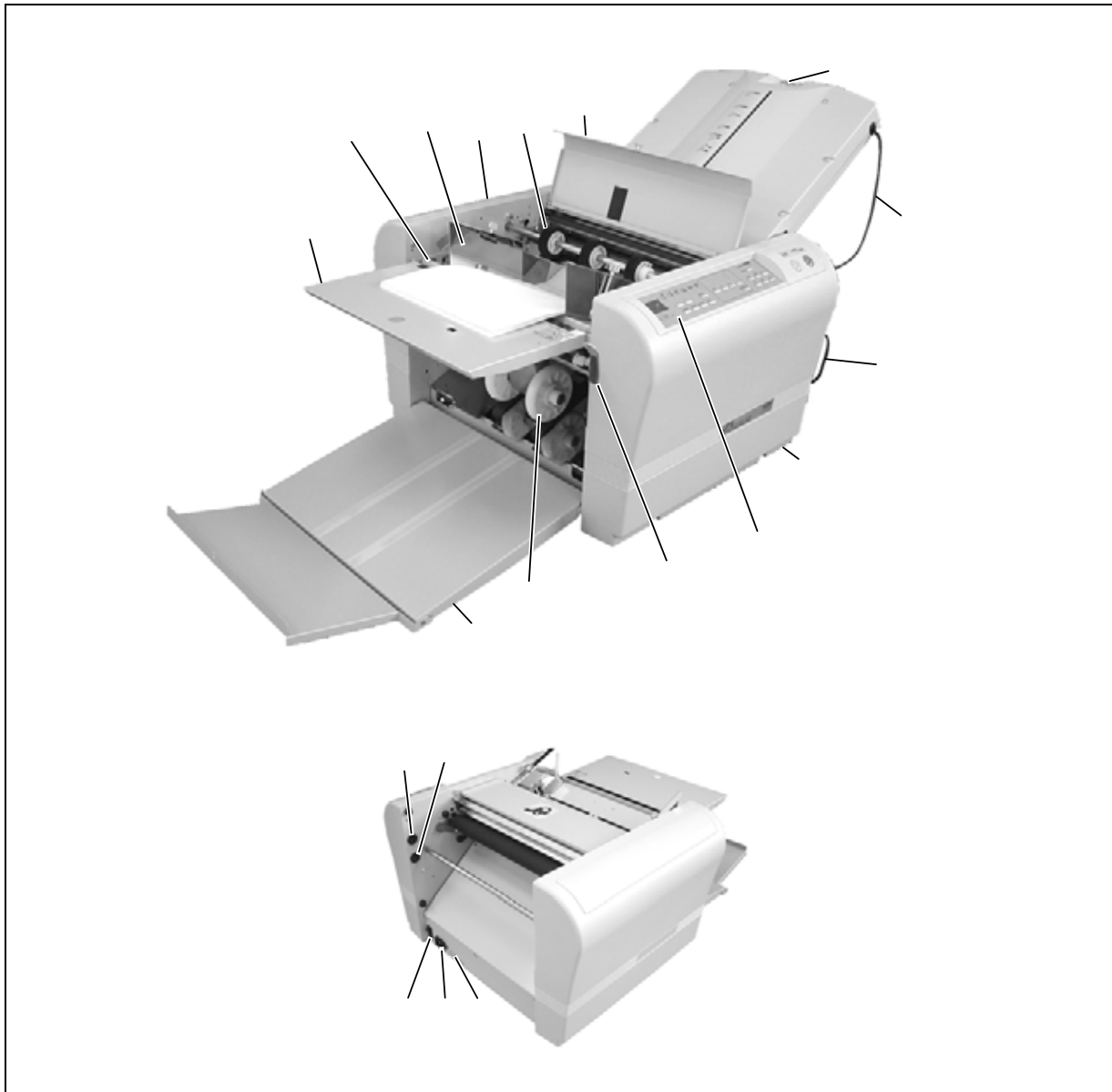

| Number | Name                         | Number | Name                               |
|--------|------------------------------|--------|------------------------------------|
| ①      | Safety cover                 | ⑩      | Paper feed table                   |
| ②      | Left side cover              | ⑪      | Table 2                            |
| ③      | Paper feed roller            | ⑫      | Right side cover                   |
| ④      | Paper guide                  | ⑬      | Paper feed table lever (307A only) |
| ⑤      | Auxiliary feed table         | ⑭      | Table 1 socket                     |
| ⑥      | Paper eject roller           | ⑮      | Table 2 socket                     |
| ⑦      | Paper eject table            | ⑯      | Power switch                       |
| ⑧      | Stopper fine adjustment knob | ⑰      | Inlet                              |
| ⑨      | Table 1                      | ⑱      | Circuit breaker                    |
| ⑩      | Control panel                |        |                                    |

## (4) Designation and Functions of Operations Panel

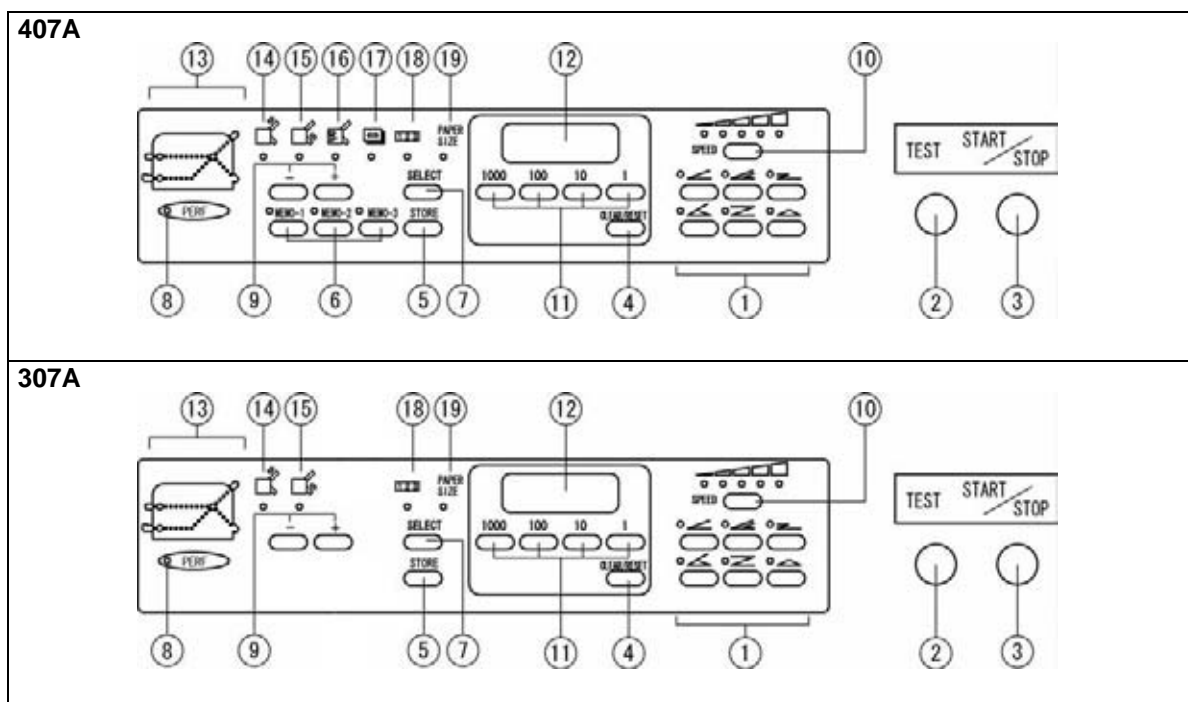

| No. | Designation/Indication          | Function   |
|-----|---------------------------------|--|
| ①   | Fold type key                   | Six fold types can be input and stored.  |
| ②   | Test key                        | Test folds two sheets without counting.  |
| ③   | Start/Stop key                  | Starts and stops machine.  |
| ④   | Clear/Reset key                 | Clears the counter / resets after an error.  |
| ⑤   | Store key                       | Fold position after adjustment is stored.  |
| ⑥   | Memory 1/2/3 key                | Three special fold types are stored. (407A only)   |
| ⑦   | Select key                      | Used for selecting the counter, the position of the stopper stud of Table 1 and 2, the position of paper eject roller, and paper length. |
| ⑧   | Perforation mode lamp           | Indicates when the optional perforating unit is installed.   |
| ⑨   | + / - key                       | Used for adjusting the position of the stopper of Table 1 and 2, the position of paper ejection roller, and paper length                 |
| ⑩   | Speed adjustment key            | Adjusts speed.   |
| ⑪   | Numerical key                   | Used for inputting the number of sheets to be folded and the length of non-standard size paper   |
| ⑫   | Counter                         | Shows the number of sheets, the position of the stopper pin of Table 1 and 2, and paper size.  |
| ⑬   | Check lamp                      | Indicates when paper stock runs short, or the location of paper feed trouble.  |
| ⑭   | Table 1 stopper move mode lamp  | Indicates when the position of stopper of Table 1 is adjusted.   |
| ⑮   | Table 2 stopper move mode lamp  | Indicates when the position of stopper of Table 2 is adjusted.   |
| ⑯   | Paper ejection roller move lamp | Indicates when the position of the paper ejection roller is adjusted. (407A only)  |
| ⑰   | Paper length input mode lamp    | Indicates when paper length is input (407A only)   |
| ⑱   | Counter input mode lamp         | Indicates when reduction is indicated on the counter.  |
| ⑲   | Paper size input mode lamp      | Indicates paper size.  |

## (5) Operation of the Counter

### (A) Addition Counter

The number indicated on the counter increases by one each time a sheet of paper is folded.

Press the Select key and select the Counter Input Mode Lamp

123.

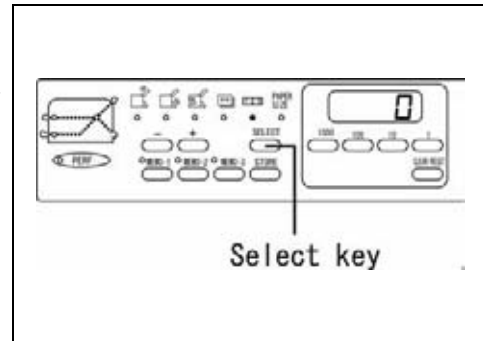

Press the Clear/Reset key and reset the number to zero (0).

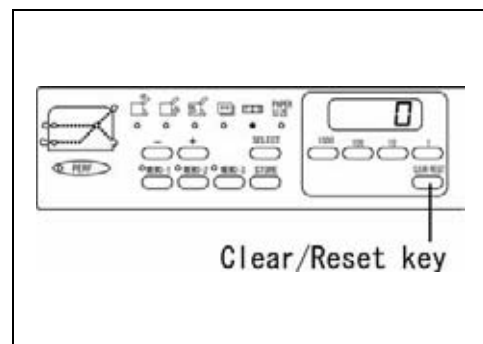

### (B) Subtraction Counter

The number indicated on the counter decreases by one each time a sheet of paper is folded.

Press the Select key and select the Counter Input Mode Lamp

123.

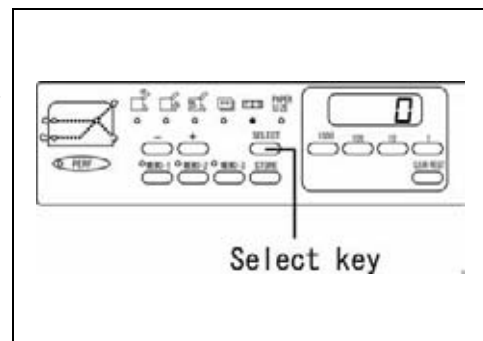

Input the desired number using the Numerical keys.

(20 is input in this case)

Subtraction Mode Lamp will light.

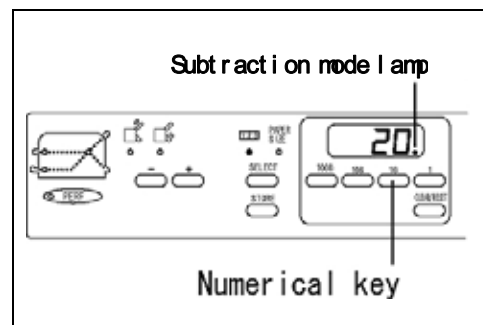

## (6) Set-Up

Install Table 1 and 2.

Insert the notched front part of Table 1 into stud ① and drop its rear notched part onto stud ②. Insert the plug into the connector ③.

**Caution:**

The connector can only be connected one way. Do not force.

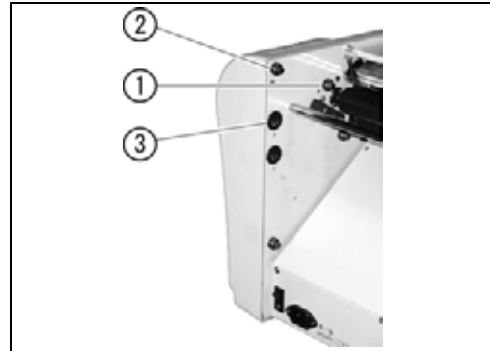

Insert the notched front part of Table 2 into stud ④ and drop its notched rear part onto stud ⑤. Insert the plug into the connector ⑥.

**Caution:**

The connector can only be connected one way. Do not force.

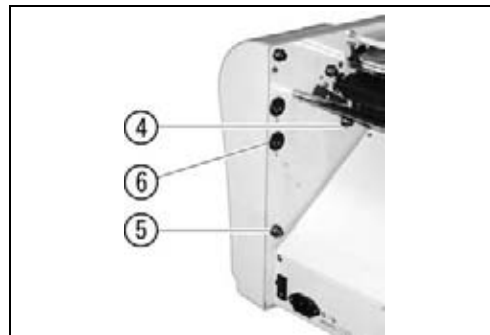

Pull the paper eject table out and lift the auxiliary feed table into position.

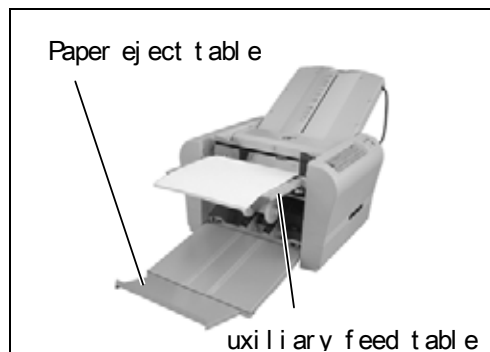

Insert the power cord into an outlet.

**Caution:**

Do not use a power cord other than the one provided.

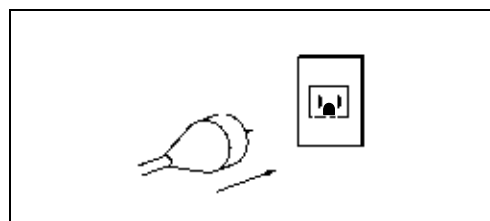

Insert the power cord into the inlet.

When the power switch is turned on, the stoppers of Table 1 and 2 move to the zero position.

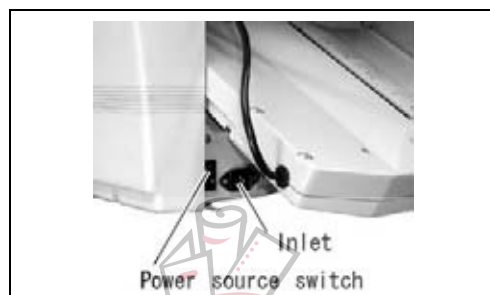

## (7) Directions for Use

### (A) Standard folding of standard-size paper

#### 407A

1. Turn power switch on.
2. Loosen the paper guide set screw and adjust the paper guide to fit the width of the paper.
3. Neatly arrange and place it on the feed table with the printed side up (printed side down in case of fold-out).
4. Adjust paper guide snug with the paper, and tighten the setscrew.

< to next page >

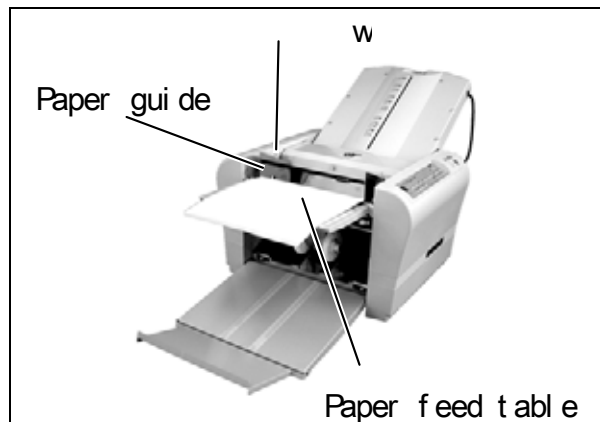

#### 307A

1. Turn power switch on.
2. Raise the paper feed table lever.
3. Loosen the paper guide set screw and adjust the paper guide to fit the width of the paper.
4. Neatly arrange and place it on the feed table with the printed side up (printed side down in case of fold-out).
5. Adjust paper guide snug with the paper, and tighten the setscrew.
6. Lower the paper feed table lever.

< to next page >

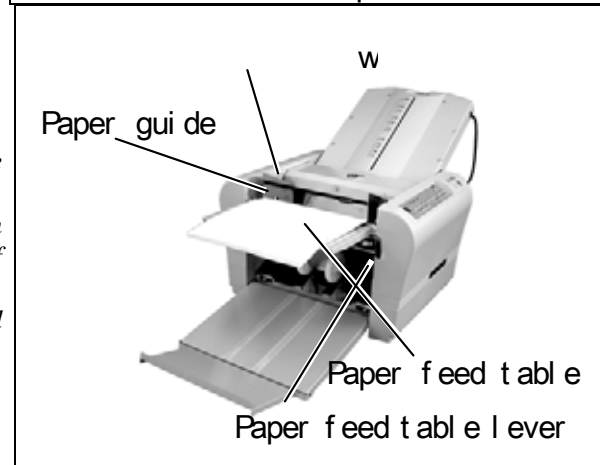

#### **Setting the paper exit roller (307A only):**

The exit roller should be moved to the proper position according to the paper size. Refer to the "Roller Position Indication" label. If ejection is not performed properly, try a different position.

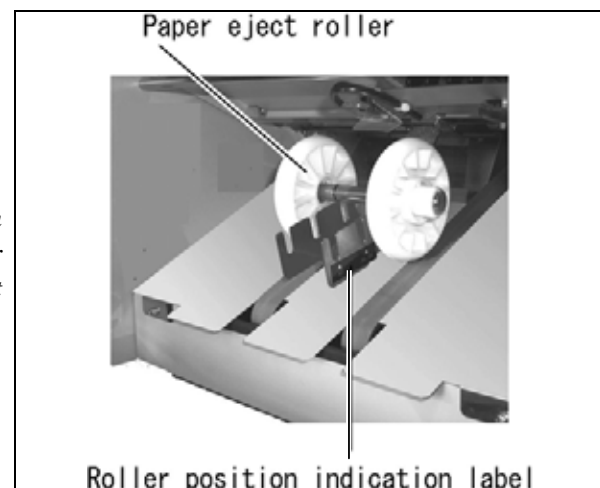

**Selecting a fold type:**

One of the six folding types (Single, Gate, Letter, Zigzag, Double Parallel, and Fold-out) can be selected. Press the desired fold type key.

**Example:**

Single folding using letter size paper.

Letter size (11" length) – C1

Legal size (14" length) – C2

Ledger size (17" length) – C3

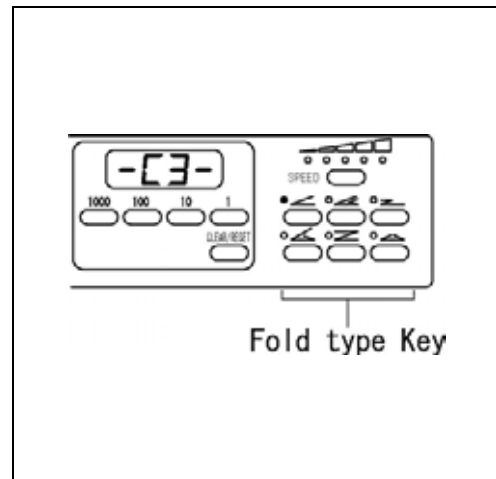

**Test folding:**

When the TEST key is pressed, two sheets will be folded while not activating the counter. Check to see if the second sheet has been folded correctly. To correct skews refer to Adjustment on page 17.

**Caution:**

In case the stopper fine adjustment knob is moved, make sure to press TEST key for confirmation before START key is pressed. Otherwise, fine adjustment will not be recognized.

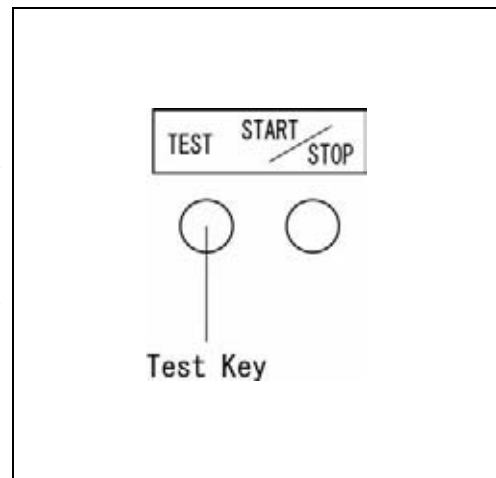

**Continuous folding:**

When the START / STOP key is pressed, the machine will continuously fold.

When the START / STOP key is pressed while the machine is in operation, the machine will stop, but addition on the counter will continue. If you wish to fold only the number of sheets desired, use the subtraction counter function.

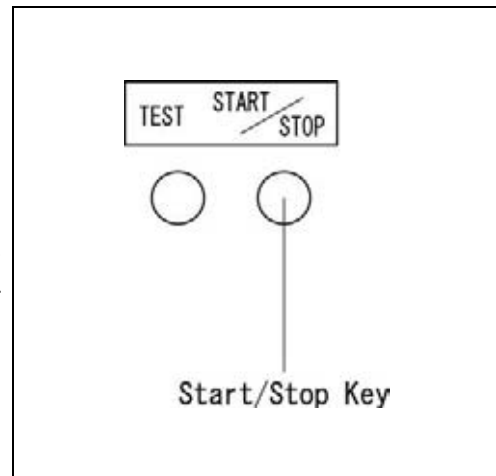



## (B) Standard Folding of Non-standard-size Paper

### Determine the Paper Length

Measure the paper length.

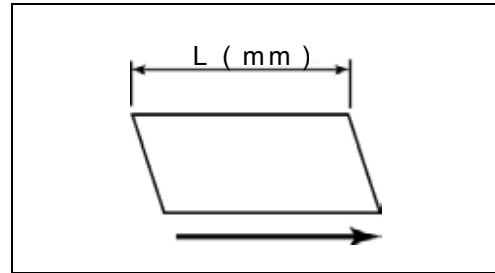
The arrow indicates the direction of paper feed.



Press the SELECT key and select the Paper Length Input Mode. 

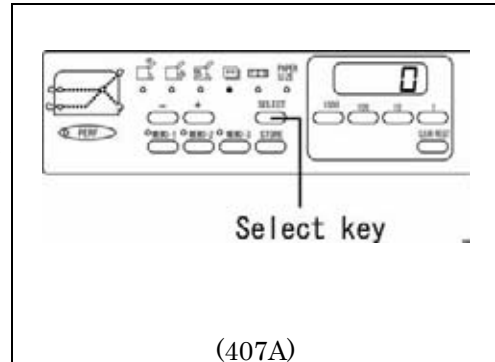

Input the paper length using the number keys.

**The unit for input is millimeters.**

**For example, to specify a paper length of 250 mm, enter 2 → 5 → 0.**

The available input range is 179 to 435 mm.

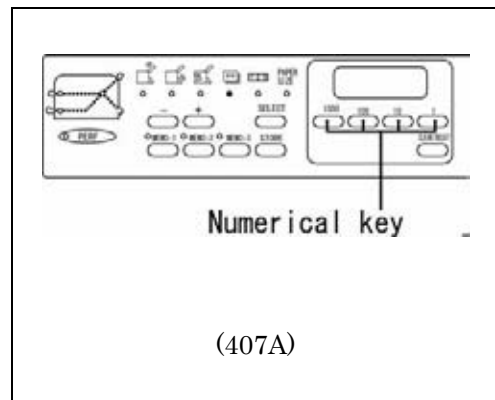

### Setting the paper eject roller (407A)

Select the paper ejection roller move mode using the SELECT key.

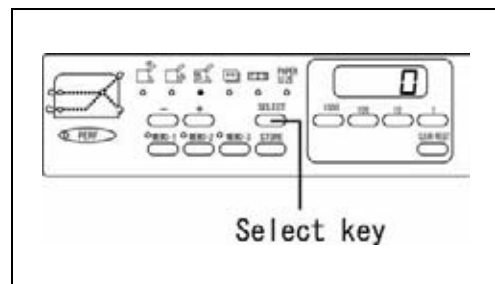

Set the designated position using the +/- key.

|                         |                                 |    |    |
|-------------------------|---------------------------------|----|----|
| Indication              | 1                               | 2  | 3  |
| Standard-size paper     | C1                              | C2 | C3 |
| Non-standard-size paper | Setting the designated position |    |    |

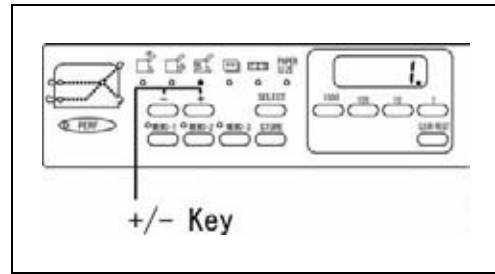

### Setting the paper ejection roller for( 307A)

The exit roller should be moved to the proper position according to the paper size. Refer to the “Roller Position Indication” label. If ejection is not performed properly, try a different position.

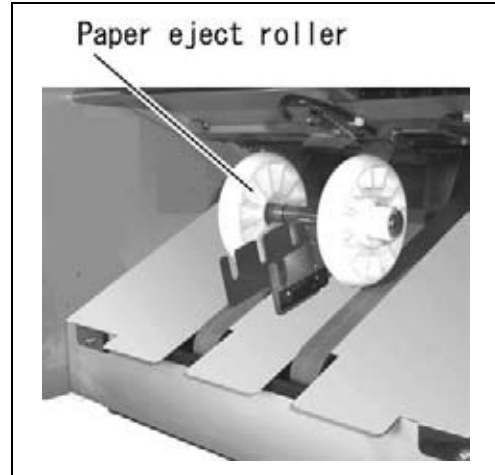

### Fold-Stopper Position Chart

**Note:**

Calculate the position of table 1 and 2 stoppers in relation to the measurement value L on page 12.

**Example:**

In the case of performing the zigzag fold using sheets of paper 300mm in length:

Table 1 =  $300 \times (2 / 3) = 200\text{mm}$

Table 2 =  $300 \times (1 / 3) = 100\text{mm}$

|                   | Table 1           | Table 2 |
|-------------------|-------------------|---------|
| SINGLE            | Original position | 1/2     |
| GATE              | 1/4               | 1/2     |
| LETTER            | 1/3               | 1/3     |
| ZIGZAG            | 2/3               | 1/3     |
| DOUBLE            | 1/2               | 1/4     |
| PARALLEL FOLD-OUT | 3/4               | 1/4     |

## (C) Cross Folding

Cross folding refers to performing the double parallel, letter, or other types of folds for paper already folded using a single fold.

Cross folding can be used when, for example, a sheet of ledger size paper folded using the double parallel fold is still too large to be enclosed in an envelope.

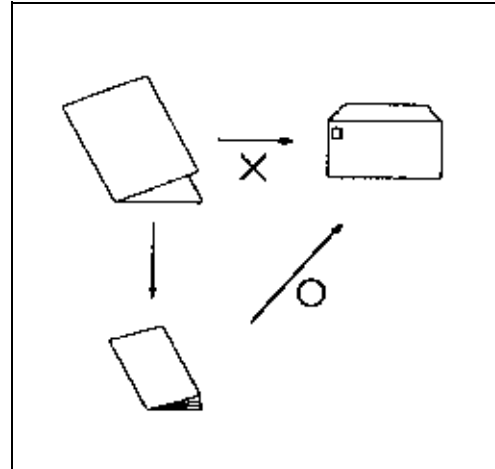

### Note:

The maximum weight of paper that can be used for cross folding is 28lb. bond. This may vary due to the following conditions:

- Paper type and size
- Direction of grain
- Temperature and relative humidity
- Printing condition

The fold position may be displaced to a greater extent than when using a regular fold method. Also, a corner of the paper may be folded inside as indicated in the figure at right. This does not mean that the machine has malfunctioned.

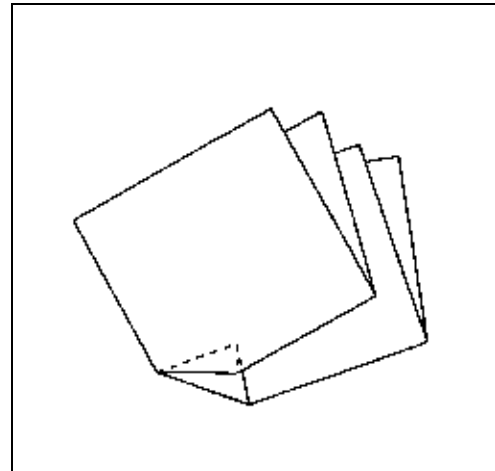

### Note:

- 1.) Move the paper feed rollers on both sides to proper position in advance so that all of the rollers can feed correctly.
- 2.) Flatten the crease firmly. Do not stack too many sheets of paper on the feed table.
- 3.) Use paper support guide(s) to help hold paper down

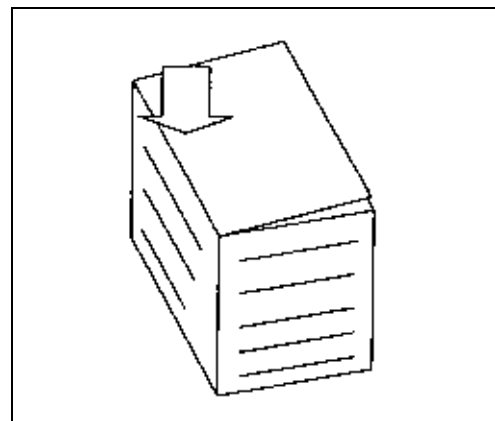

## (8) Adjustment

### (A) Skew Adjustment

If the folding position is slanted it can be adjusted using the skew adjustment knob.



### (B) Fine Adjustment

Move the stopper using the stopper fine adjustment knob.

**Caution:** If the fine adjustment knob is moved, when the TEST key is pressed, the machine will continue to fold, when the START / STOP key is pressed, the machine will start to fold after the stopper is returned to the previous position



#### Note:

To make large stopper adjustments, use the +/- key.

#### Adjusting Table 1

Press the Select key and select the Table 1 Stopper Move Mode.

Press the +/- key and move the stopper to the desired position.

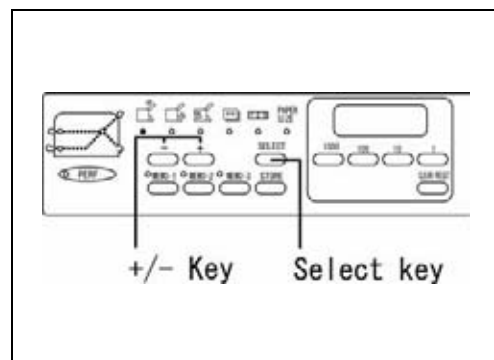







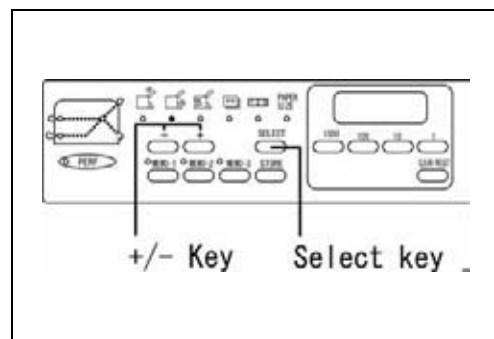







#### Adjusting table 2

Press the Select key and select the Table 2 Stopper Move Mode.



















Press the +/- key and move the stopper to the desired position.



## Fine Adjustment for Table 1

| Fold type            |   | Folded (A) | Direction to turn the Table 1 fine adjustment knob                                    |
|----------------------|---|------------|---|
| Single fold          | Table 1 is not used   |            |   |
| Gate fold            |    | Long       |    |
|                      |   | Short      |    |
| Letter fold          |    | Long       |    |
|                      |   | Short      |    |
| Zigzag fold          |   | Long       |   |
|                      |   | Short      |  |
| Double parallel fold |  | Long       |  |
|                      |   | Short      |  |
| Fold-out Fold        |  | Long       |  |
|                      |   | Short      |  |

## Fine Adjustment for Table 2

| Fold type            |   | Folded (B) | Direction to turn the Table 2 fine adjustment knob                                    |
|----------------------|---|------------|---|
| Single fold          |    | Long       |    |
|                      |   | Short      |    |
| Gate fold            |    | Long       |    |
|                      |   | Short      |    |
| Letter fold          |    | Long       |    |
|                      |   | Short      |   |
| Zigzag fold          |  | Long       |  |
|                      |   | Short      |  |
| Double parallel fold |  | Long       |  |
|                      |   | Short      |  |
| Fold-out fold        |  | Long       |  |
|                      |   | Short      |  |

# (9) Memory (A) Storage

## 407A

Storage of Non-standard folds can be input with the Memory 1/2/3 keys and the Fold type keys.

The positions of the Table 1 and 2 stoppers, position of the ejection roller, and folding speed are all saved in memory.

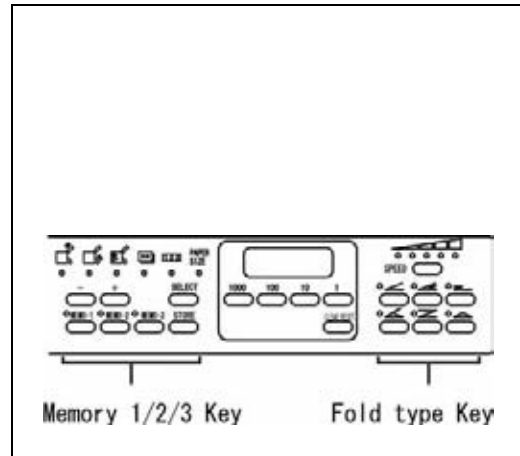

## 307A

*Storage of Non-standard folds can be input with the Fold type keys.*

*The position of the Table 1 and 2 stoppers, and folding speed is stored in memory.*

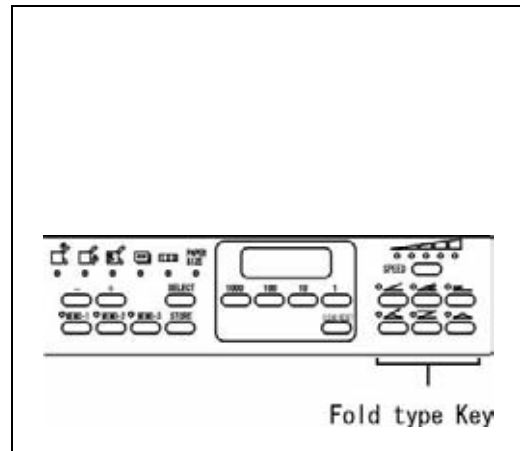

Select the memory key in which the fold will be input.  
Hold down the STORE key and release immediately when you hear a beep.

The lamp of the key in which the fold has been input will flash.

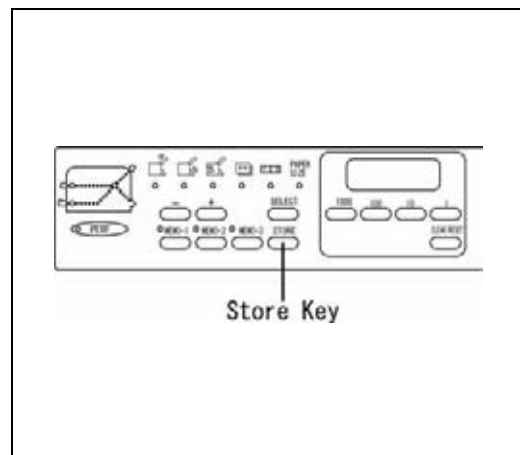

## (B) Cancellation of Memory

**Cancel the storage input in the memory 1/2/3 keys and the fold type keys**

**Important:**

The machine will be enabled to perform standard folds set by the manufacturer.

Select the key in which the memory is to be cancelled.

**Important:**

The lamp of the key in which the fold is stored flashes.

Press and hold the CLEAR / RESET key and release immediately when you hear a beep.

The lamp of the key in which the storage has been cancelled will light.

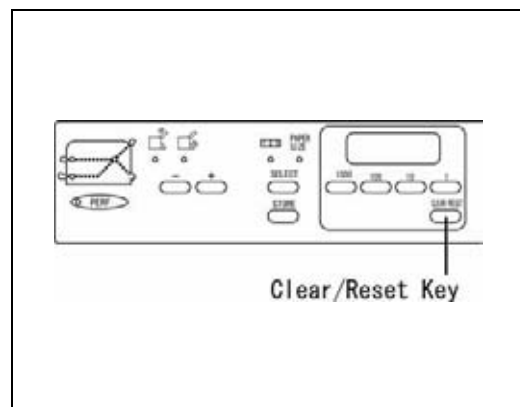

## (C) Cancellation of total memory

**Cancel all storage input in all the keys.**

**Important:**

The machine will be enabled to perform standard folds set by the manufacturer.

Press and hold the CLEAR / RESET key and release immediately when you hear a beep.

The lamp for the key of which the storage has been cancelled will light.

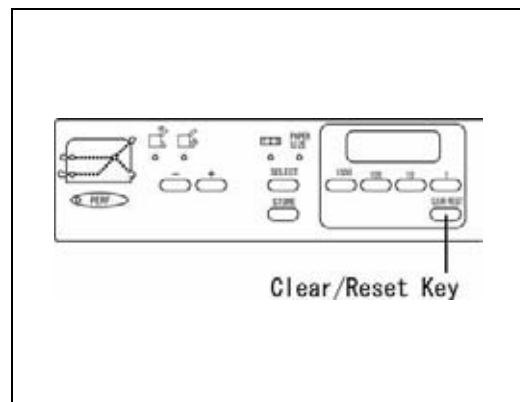

## (10) Maintenance

Two rollers can be removed and installed without using any tool, which facilitates cleaning of the rollers and paper ejection photo sensor.

As the other two rollers cannot be removed, they should be cleaned while revolving them little by little. Rollers should be moistened with water and wiped off with a cloth wrung tightly.

If only one sheet of paper is fed, use a soft cotton swab to remove paper dust, etc. from the face of the paper ejection photo sensor shown by the arrow.

### (1) Removing the rollers

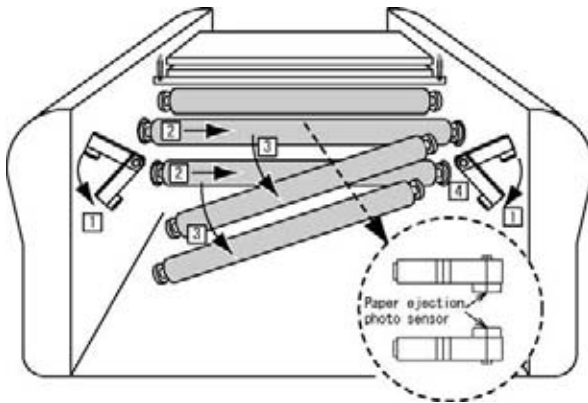

Remove the upper roller in the order of **1** to **3**, and then remove the lower roller.

- 1** Move down the roller setting lever to the OFF position.
- 2** Slide the roller to the right.  
(Its shaft will come off from the left-side hole.)
- 3** Remove the roller from the right-side hole.

### (2) Setting of the rollers

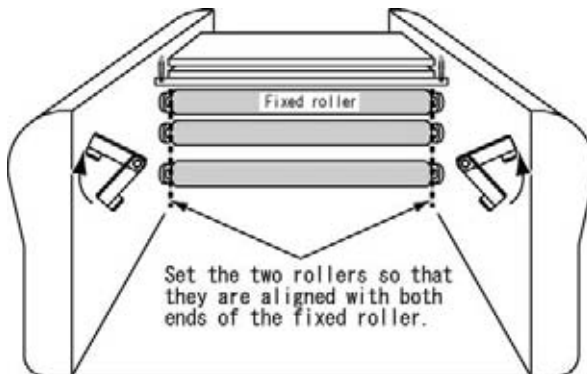

In the reverse order of removal, set the lower roller first.

- [1] Insert the roller deep to the right.
- [2] Slide the roller to the left.

\* Be careful not to let the roller shaft on both sides get stuck on Part A.



As shown above, the roller shaft should be placed on Part A.

- [3] Move up the roller setting lever to the ON position.

### **Caution!**

If the roller is not firmly fixed, it may cause operating problems. If it cannot be fixed, contact your dealer.



Paper ejection photo paper

<Cleaning the paper feed photo sensor>

Open the safety cover and wipe the surface (black plastic) of the paper feed photo sensor with the tip of a cotton swab or similar material moistened in water.

**Caution!**

When cleaning, make sure that no residue from the cotton swab is left in the unit or the paper feed may stop with an error after feeding a single sheet (Check lamp (1) flashes).  
→ See "(11) Troubleshooting, Check lamp (1)" on page 22.

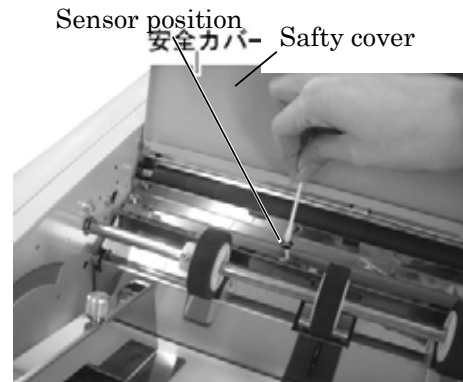

When replacing the paper feed roller and paper separator, proceed in the order (1) → (2).

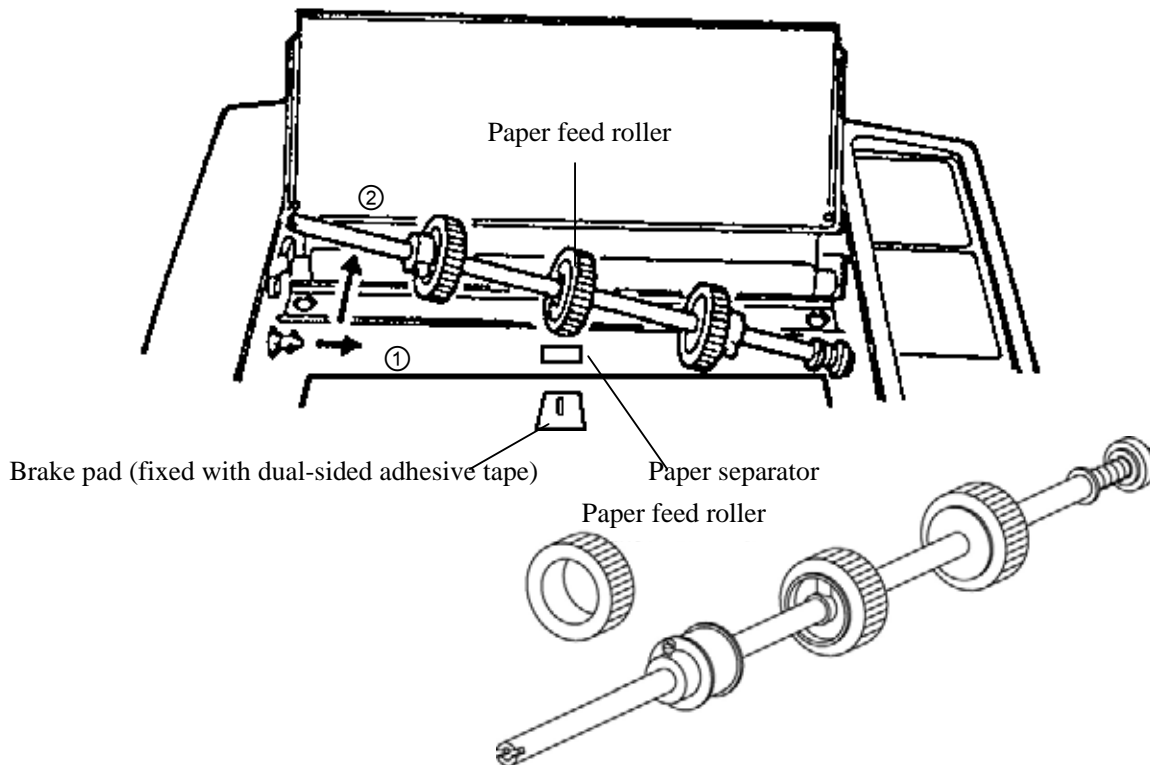

Grasp the paper separator (with plastic part) at both ends and pull it out. To install, reverse the procedure.

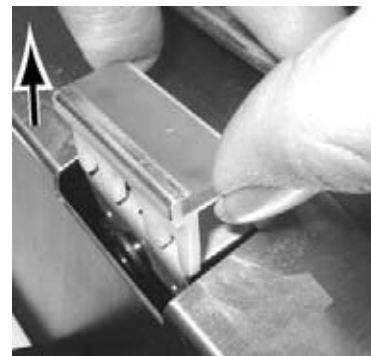
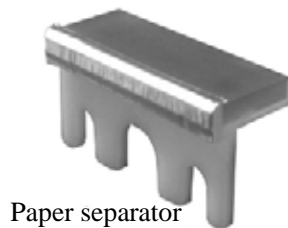

To order the parts above, please contact your dealer.

## (11) Troubleshooting

If Check lamp (1) is flashing it may indicate:

- 1) No paper
- 2) Paper jam at paper feed photo sensor
- 3) Paper feed photo sensor is dirty

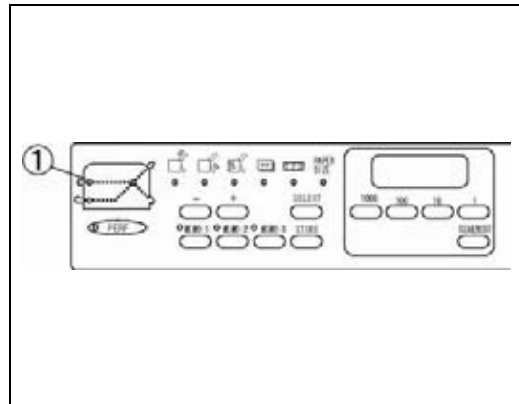

If Check lamp (2) is flashing it may indicate:

- 1) Paper jam at fold tables
- 2) Plug is disconnected

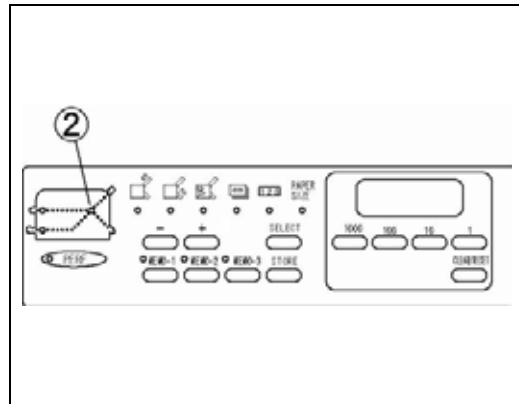

If Check lamp (3) is flashing it may indicate:

- 1) Paper jam at paper eject photo sensor
- 2) Paper eject photo sensor is dirty

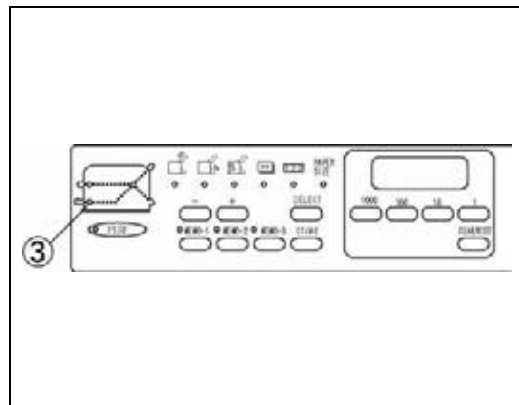

### Note:

**If paper is loaded immediately after printing, problems such as jamming, double feed, slipping, and wrinkling may occur. Make sure that the paper is completely dry before loading.**

If the unit is placed in the vicinity of a fluorescent lamp that operates irregularly, the paper size detection sensor may not function properly. In such a case, increase the distance between the unit and the fluorescent lamp.

## (12) Removing the fold tables

(1) Set the power switch to OFF.



(2) Disconnect the plugs.

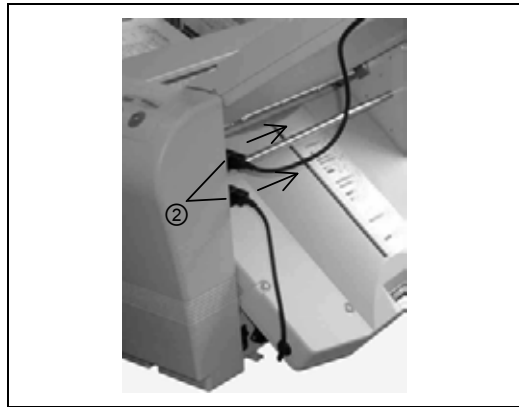

(3) Remove the fold tables.

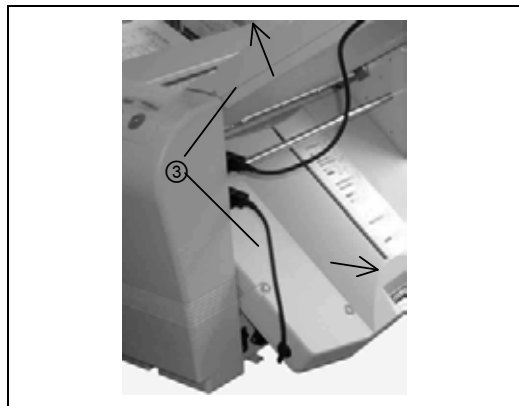

### **Caution!**

Be sure to always remove plugs prior to removing tables.

**MEMO**

**MEMO**



**MBM Corporation**



# We Have it All...



## **MyBinding.com** *When Image Matters.*

**Guaranteed Lowest Prices** on an  
Endless Selection of Binding Systems, Laminators,  
Paper Shredders, Supplies and Accessories.

**We have you covered** with Expert Advice  
and Support. Our popular blog keeps you up to  
date on the latest tips and techniques to make  
your most important binding and laminating  
tasks a success.

**Call Us Today**

**1-800-944-4573**

### **Our Trusted Partners**

GBC / Ibico  
Fellowes  
Powis Fastback  
Unibind  
Akiles  
Renz  
Tamerica  
Rhin-O-Tuff  
DFG

Pro-Bind  
Martin Yale  
MBM  
Formax  
Intimus  
Dahle  
HSM  
Standard  
Xyron

Challenge  
Lasko-Wizer  
GBC Shredmaster  
Avery  
Wilson Jones  
Cardinal  
Samsill  
Universal

- BINDING MACHINES
- BINDING SUPPLIES
- LAMINATORS
- I.D. ACCESSORIES
- BOARDS & EASELS
- PAPER SHREDDERS
- XYRON LAMINATORS
- COIL BINDING MACHINES
- UNIBIND BINDING MACHINES
- FASTBACK BINDING EQUIPMENT
- PAPER FOLDING MACHINES
- LAMINATING POUCHES
- ROTARY TRIMMERS
- CLEAR COVERS
- TWIN LOOP WIRE
- REGENCY COVERS
- PLASTIC BINDING COVERS
- VELOBIND BINDING MACHINES
- PAPER HANDLING EQUIPMENT
- THERMAL BINDING MACHINES
- PROCLICK BINDING SYSTEMS
- COMB BINDING MACHINES
- COMB BINDING SUPPLIES
- WIRE BINDING MACHINES
- POUCH LAMINATORS
- LAMINATING ROLLS
- 3-RING BINDERS
- ROLL LAMINATORS
- VELOBIND SPINES
- PAPER CUTTERS
- PAPER JOGGERS
- LETTER OPENERS
- THERMAL COVERS
- UNIBIND SUPPLIES
- PROCLICK SPINES
- ZIPBIND SPINES
- LINEN COVERS
- SPIRAL COIL
- INDEX TABS

