

# GBC Velobind System Three Pro

## Users Manual



Provided By

**MyBinding**.com®  
*When Image Matters.*

# GBC/VeloBind System Three Pro GBC/SureBind System Three Pro

Assembly Numbers 9707048 (GBC/VeloBind) & 9707047 (GBC/SureBind)

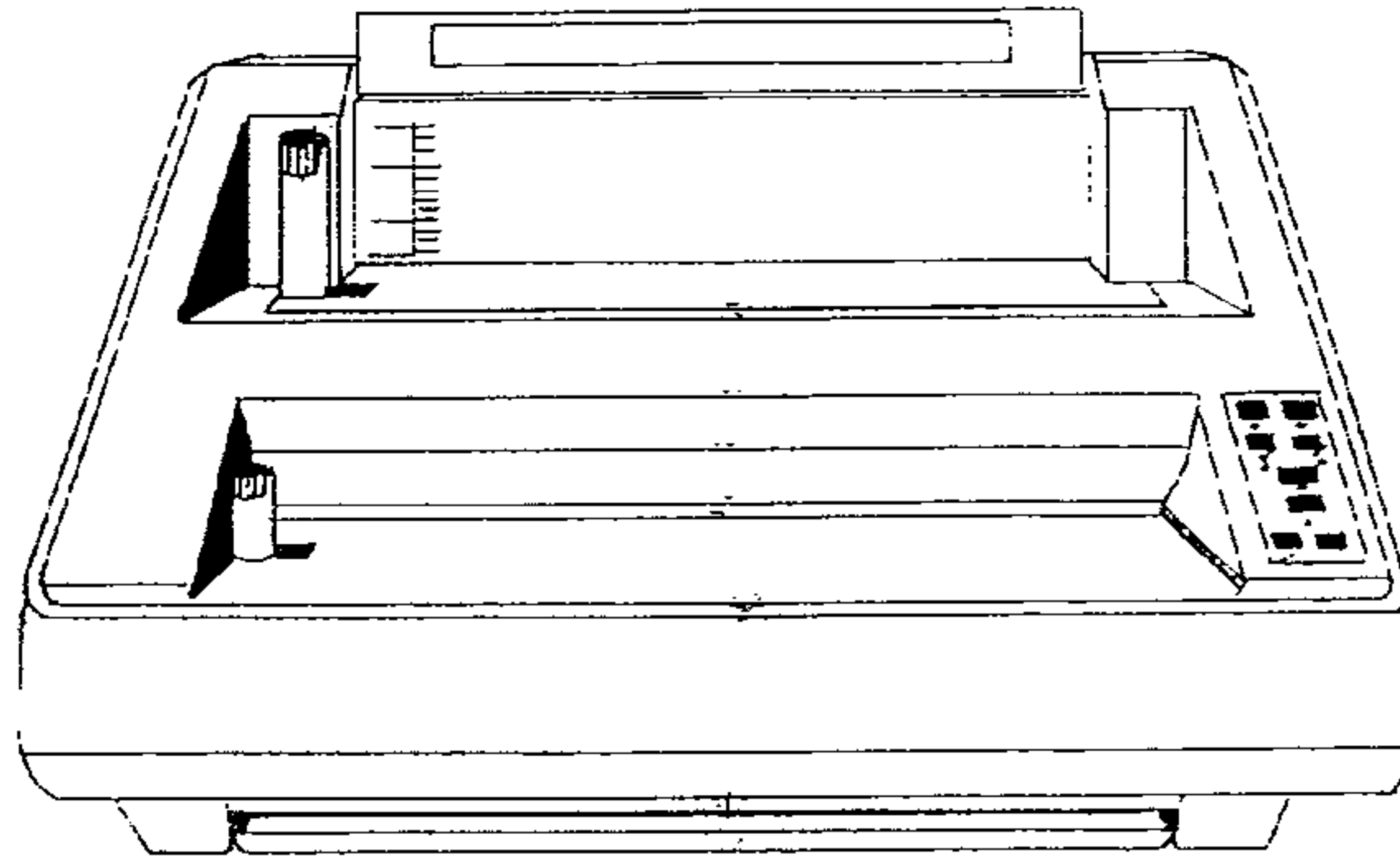

GBC National Service Department  
Printed in U.S.A.  
Part No. 6001006  
Issued 8/95

©Copyright General Binding Corporation, Northbrook, IL U.S.A.

## 4.0 OPERATING INSTRUCTIONS

### 4.6 DEBINDING

1. Place document to be debound as follows:
  - A. Bound edge against Backstop "E".
  - B. Small hole in bottom strip over Locating Pin "D".
  - C. Edge of document next to Bind Edge Guide "B".
2. Once the document to be debound is properly located, press the Debind Button "M" to place in debind mode.
3. Lower the Pressure Bar "C" onto document, and the machine will go through the debinding cycle.
4. Immediately after the Pressure Bar "C" raises (approximately 25 seconds), remove the document and peel the top strip off.
5. Press either Standard Bind Button "K", or Fast Bind Button "L" to place the machine back in binding mode.

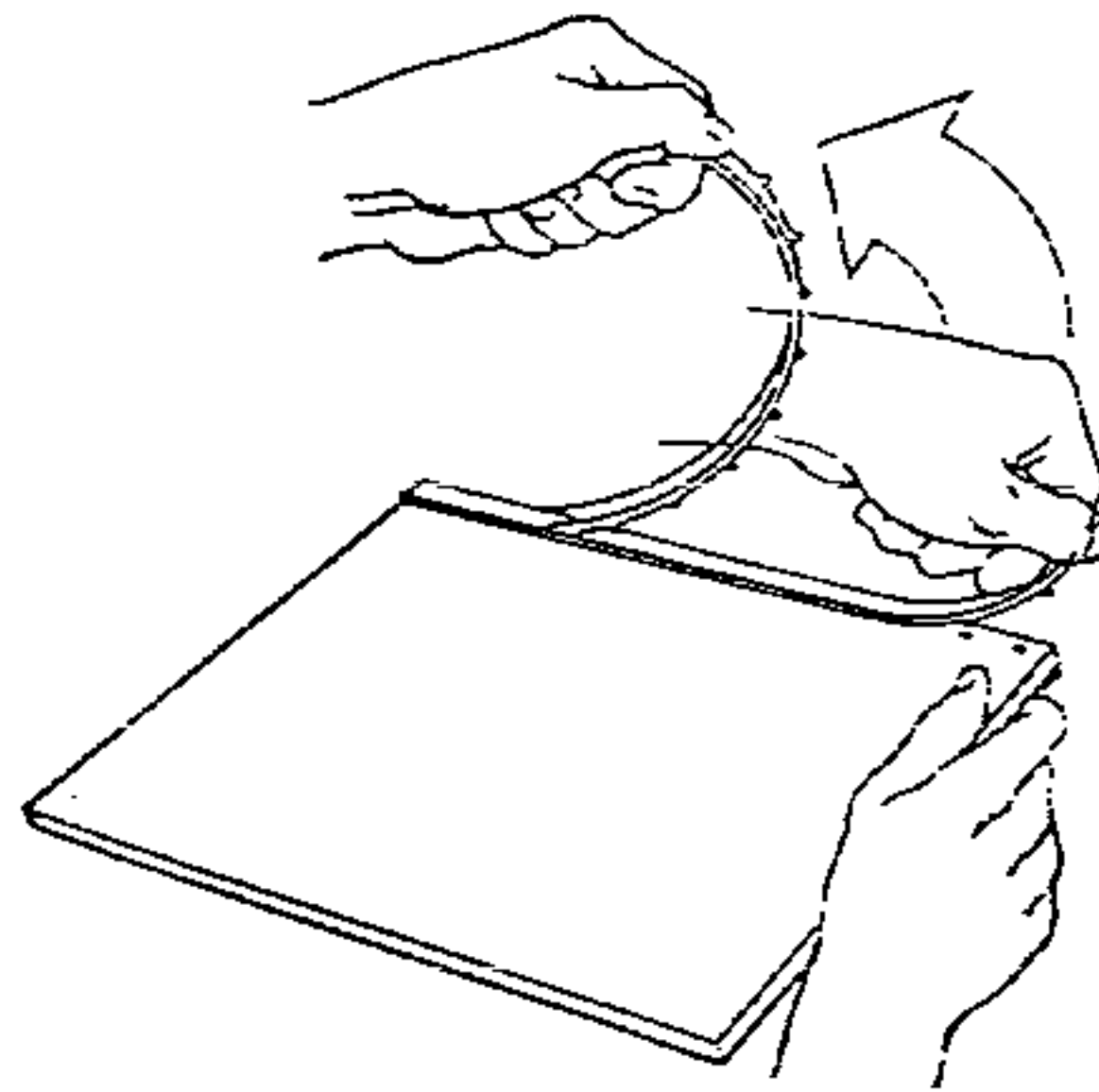

Figure 4-5

## 4.0 OPERATING INSTRUCTIONS

### 4.4 DOCUMENT ASSEMBLY

1. Insert the bottom strip (strip with holes) into the Strip Recess "F", textured side down, fitting the small hole in strip over the Locating Pin "D" which protrudes slightly from the bottom surface of the Strip Recess "F". Note: The position of the Locating Pin is indicated by the arrow painted on the Backstop "E". When the strip is correctly positioned, the hole closest to the left end of the strip will be aligned with the vertical line on the Backstop "E".
2. Place the punched document face up (first sheet on top and last sheet on bottom) on the Bind Platen "G", with the left edge of the document next to the Bind Edge Guide "B", and the punched edge resting against the Backstop "E". Note: The Bind Edge Guide "B" is properly adjusted when the punched holes of the document are aligned with strip holes and the left edge of the document is resting next to the Bind Edge Guide "B".
3. The maximum binding capacity of the machine is 3 inches. If document is to be enclosed in a soft cover, the front and back covers must be assembled as shown in Figure 4-3, and bound into the document at this time. If document is to be enclosed in a hard cover, VeloBind endsheets must be bound into the document at this time. The endsheets are placed on the front and back of the document with the printed release paper facing out, and the plain white sides facing the first and last sheets of the document (The hard cover will be attached to the document after the binding is completed.)
4. Insert the top strip (strip with pins) into the holes in the document and bottom strip. Press the top strip down firmly until it contacts the top sheet of the document.

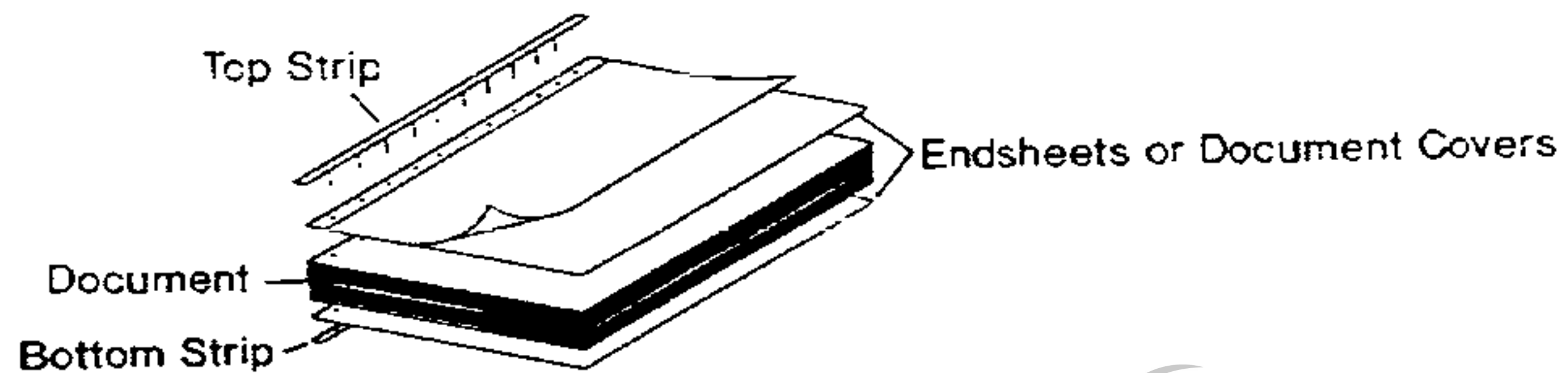

Figure 4-3

## 4.0 OPERATING INSTRUCTIONS

### 4.2 OPERATIONAL COMPONENTS DESCRIPTION

- A. **PUNCH EDGE GUIDE:** Adjustable guide used to position document to be punched. In "auto" punch mode, inserting document next to this guide activates punch cycle immediately.
- B. **BIND EDGE GUIDE:** Adjustable guide used to align documents for the binding and debinding cycle.
- C. **PRESSURE BAR:** Exerts pressure on and holds document in place during the binding and debinding cycle.
- D. **LOCATING PIN:** Centers the strip pins for binding and debinding. The small hole in the bottom strip must be placed on this pin for proper machine operation.
- E. **DOCUMENT BACKSTOP:** Serves to position document correctly, along with the locating pin and bind edge guide, so holes are aligned for easy insertion of top (pin) strip. The scale on the backstop measures document thickness for selection of pin strip length, or appropriate hard cover size.
- F. **STRIP RECESS:** The strip recess supports the bottom strip.
- G. **BIND PLATEN SURFACE:** Surface where document is placed for binding after it is punched.
- H. **PUNCH PLATEN SURFACE:** Surface where document is placed for punching holes.
- J. **DEBRIS TRAY:** Located in base of machine, collects excess paper and strip debris, and contains operating instructions. Empty frequently.
- K. **OVER 1" BUTTON:** Pressing this button places the machine in standard bind mode. The standard bind mode is recommended for documents where maximum binding strength is required.
- L. **1" AND UNDER BUTTON:** Pressing this button places the machine in fast bind mode. Bind cycle is cut in half from standard bind mode.
- M. **DEBIND BUTTON:** Pressing this button places machine in debind mode for debinding documents.
- N. **AUTO PUNCH BUTTON:** Pressing this button allows the operator to actuate the punch cycle automatically by placing the paper stack next to the punch edge guide.
- O. **WAIT LIGHT:** Illuminates after On Button pressed - indicates machine is in warm-up mode. Goes out when machine is ready.
- P. **READY LIGHT:** Illuminates after approximately 45 seconds. Indicates machine is ready to bind.
- Q. **MANUAL PUNCH BUTTON:** In manual mode, this button must be depressed in order to punch the paper stack.
- R. **LED DISPLAY:** Allows technician to set debind time, temperature, and to check the counter.
- S. **TRAY AJAR LIGHT:** Lights to indicate debris tray is improperly inserted into base of machine.
- T. **ON BUTTON:** Pressing this button turns machine on.
- U. **OFF BUTTON:** Pressing this button turns machine off.

## 4.0 OPERATING INSTRUCTIONS

### 4.1 OPERATIONAL COMPONENTS LAYOUT

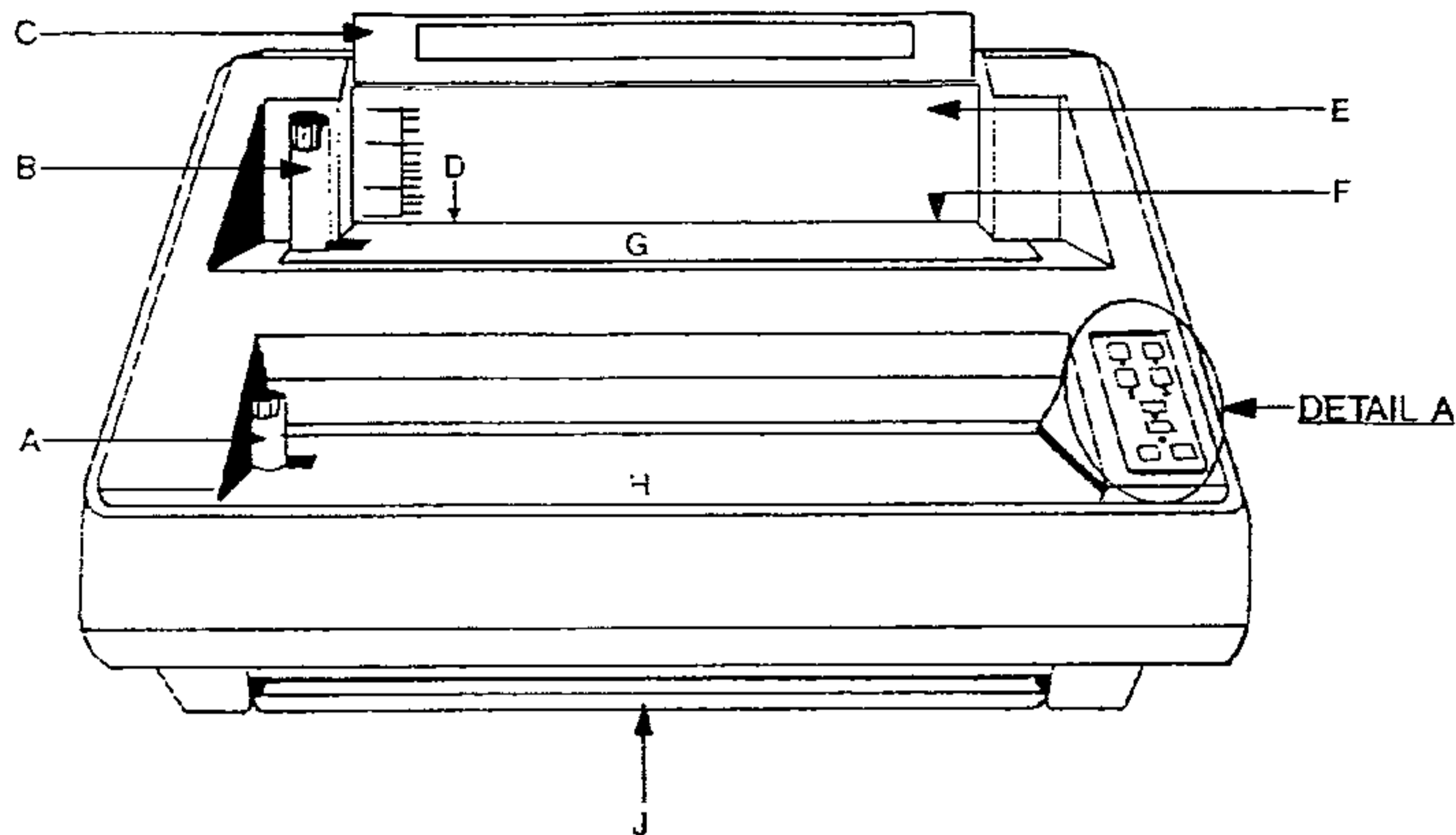
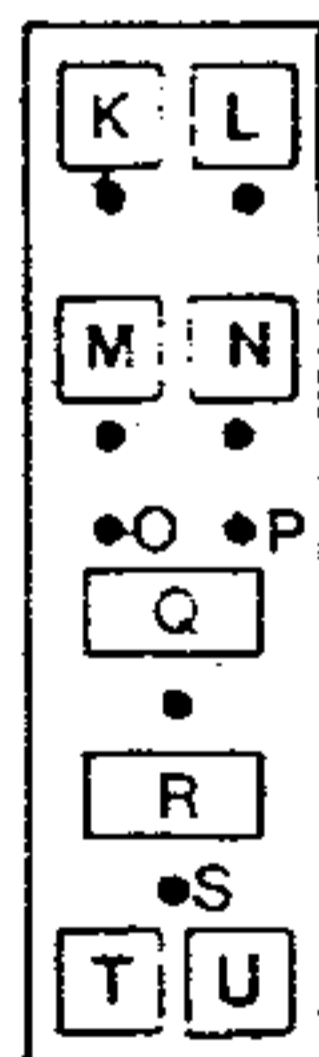

Figure 4-1

#### DETAIL A



- A. PUNCH EDGE GUIDE
- B. BIND EDGE GUIDE
- C. PRESSURE BAR
- D. LOCATING PIN
- E. DOCUMENT BACKSTOP
- F. STRIP RECESS
- G. BIND PLATEN SURFACE
- H. PUNCH PLATEN SURFACE
- J. DEBRIS TRAY
- K. OVER 1" BUTTON
- L. 1" AND UNDER BUTTON
- M. DEBIND BUTTON
- N. AUTO PUNCH BUTTON
- O. WAIT LIGHT
- P. READY LIGHT
- Q. MANUAL PUNCH BUTTON
- R. LED DISPLAY
- S. TRAY AJAR LIGHT
- T. ON BUTTON
- U. OFF BUTTON



## 4.0 OPERATING INSTRUCTIONS

### 4.3 PUNCHING

1. Push On Button "R" to turn machine on.
2. Loosen Punch Edge Guide Knob, and position Punch Edge Guide "A" so line on decal matches paper size line on Punch Platen "H". Proper positioning of the Punch Edge Guide "A" allows correct punching of your document to ensure it does not extend beyond the strip on either end when bound.
3. Select the desired punch mode
  - A. To select "Automatic Punch Mode", press Auto Punch Button "N". Insert your document into the Punch Throat squarely just to the right of the Punch Edge Guide "A" and slide your document left to the Punch Edge Guide "A" to activate the punch cycle (the metal piece you see inside the guide is the punch cycle 'trigger' or "actuator").
  - B. To punch manually, insert your document into the Punch Throat squarely next to the Punch Edge Guide "A", and press the Manual Punch Button "O".
4. Punch a test sheet of paper. Fold punched test sheet to check punch hole location and alignment from edges of paper to ensure holes are equally spaced from edges of sheet (see Figure 4-2) Adjust Punch Edge Guide "A" if necessary, and recheck test sheet punched after adjustment.
5. After ensuring your Punch Edge Guide "A" is properly positioned, tighten the Punch Edge Guide Knob, jog document to be punched so all edges are even, and insert document into Punch Throat according to step 3-A or 3-B instructions depending on punch mode selected.

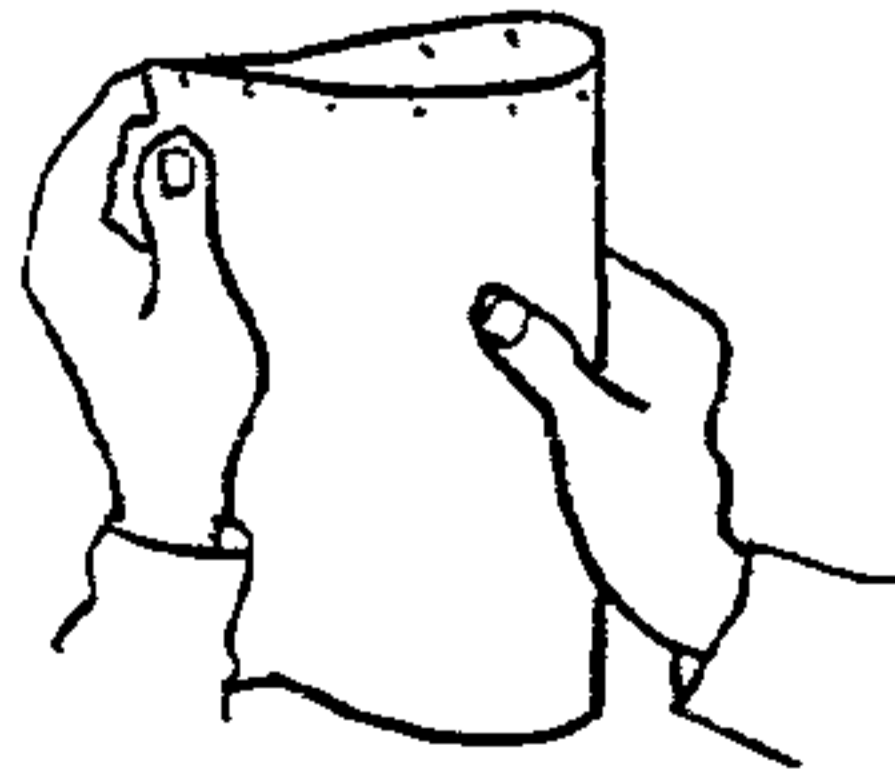

Figure 4-2  
4-3

## 4.0 OPERATING INSTRUCTIONS

### 4.5 BINDING

1. Press Bind Button "K" or Fast Bind Button "L" to place machine in desired binding mode.
2. Lower the Pressure Bar "C" onto top binding strip and document stack.
3. The binding cycle will begin immediately and automatically. When the binding process is completed (approximately 16 seconds in "standard" mode, and 10 seconds in "fast" mode), the Pressure Bar "C" will raise automatically, and the bound document can be removed.
4. The Debris Tray "J" should be checked and emptied frequently if the machine is used consistently. If periodically used, Debris Tray "J" should be checked and emptied on a daily basis. Make sure the Debris Tray "J" is reinserted properly and completely into the Base Machine will not operate if the tray is incorrectly positioned.

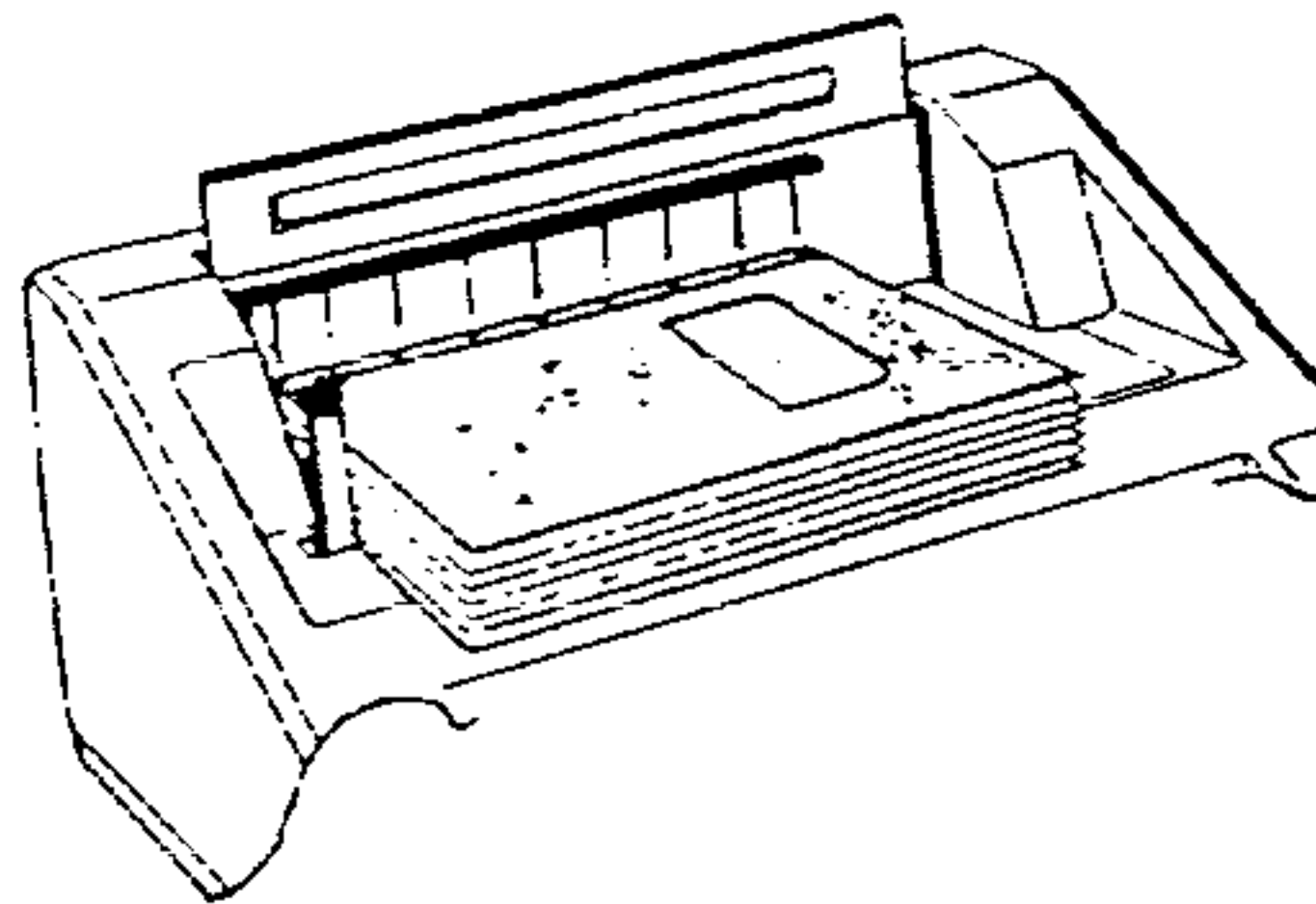

Figure 4-4

4-5

# We Have it All...



## **MyBinding.com**

*When Image Matters.*

**Guaranteed Lowest Prices** on an  
Endless Selection of Binding Systems, Laminators,  
Paper Shredders, Supplies and Accessories.

**We have you covered** with Expert Advice  
and Support. Our popular blog keeps you up to  
date on the latest tips and techniques to make  
your most important binding and laminating  
tasks a success.

**Call Us Today**

**1-800-944-4573**

### **Our Trusted Partners**

GBC / Ibico  
Fellowes  
Powis Fastback  
Unibind  
Akiles  
Renz  
Tamerica  
Rhin-O-Tuff  
DFG

Pro-Bind  
Martin Yale  
MBM  
Formax  
Intimus  
Dahle  
HSM  
Standard  
Xyron

Challenge  
Lasko-Wizer  
GBC Shredmaster  
Avery  
Wilson Jones  
Cardinal  
Samsill  
Universal

- BINDING MACHINES
- BINDING SUPPLIES
- LAMINATORS
- I.D. ACCESSORIES
- BOARDS & EASELS
- PAPER SHREDDERS
- XYRON LAMINATORS
- COIL BINDING MACHINES
- UNIBIND BINDING MACHINES
- FASTBACK BINDING EQUIPMENT
- PAPER FOLDING MACHINES
- LAMINATING POUCHES
- ROTARY TRIMMERS
- CLEAR COVERS
- TWIN LOOP WIRE
- REGENCY COVERS
- PLASTIC BINDING COVERS
- VELOBIND BINDING MACHINES
- PAPER HANDLING EQUIPMENT
- THERMAL BINDING MACHINES
- PROCLICK BINDING SYSTEMS
- COMB BINDING MACHINES
- COMB BINDING SUPPLIES
- WIRE BINDING MACHINES
- POUCH LAMINATORS
- LAMINATING ROLLS
- 3-RING BINDERS
- ROLL LAMINATORS
- VELOBIND SPINES
- PAPER CUTTERS
- PAPER JOGGERS
- LETTER OPENERS
- THERMAL COVERS
- UNIBIND SUPPLIES
- PROCLICK SPINES
- ZIPBIND SPINES
- LINEN COVERS
- SPIRAL COIL
- INDEX TABS

