

Formax FD 390 Document Folder

Instruction Manual



Provided By

MyBinding.com®
When Image Matters.

FORMAX[®]

FD 390

Document Folder

OPERATOR MANUAL
FIRST EDITION

© 2001
All Rights Reserved

WARNING

- Do not operate this machine without all guarding in place.
- Do not make adjustments or perform maintenance on this machine with power on.
- Keep the machine and the work area clean and free of spills to prevent accidents.
- Be sure to replace any safety decals that may have been detached for any reason.

FORMAX reserves the right to make changes in design or to make additions or improvements in its products without imposing any obligation upon itself to install them on its products previously manufactured. It is recommended that modifications to this equipment not be made without the advice and express written consent of FORMAX.

FOLDER IDENTIFICATION

MODEL NO: _____ SERIAL NO: _____

DEALER : _____

INSTALLED BY: _____ DATE: _____

PHONE NO: _____

Contents

| | |
|--|-----------|
| 1.0 INTRODUCTION | 4 |
| 2.0 SPECIFICATIONS | 4 |
| 3.0 INSTALLATION | 4 |
| 3.1 Unpacking & Inspection | 4 |
| 4.0 ASSEMBLY | 5 |
| 4.1 Main Unit | 5 |
| 4.2 Pump Electrical Connections | 5 |
| 4.3 Pump Hose Connections | 5 |
| 4.4 Slitter Shaft Installation | 5 |
| 4.5 Delivery Table | 6 |
| 4.6 Feed Table Assembly Installation | 6 |
| 4.7 Fold Plate Installation | 7 |
| 5.0 ELECTRICAL ACCESS | 7 |
| 6.0 FEED TABLE SETUP | 7 |
| 6.1 Setting the Controls | 7 |
| 6.2 Paper Size and Type of Fold | 7 |
| 6.3 Paper Stop Adjustment | 8 |
| 6.4 Gap Adjustment | 8 |
| 6.5 Feed Table Adjustment..... | 9 |
| 6.6 Air Blow Adjustment | 9 |
| 7.0 OPERATION | 9 |
| 7.1 Loading of Feed Table | 9 |
| 7.2 Starting the Vacuum/Air Feeder | 9 |
| 7.3 Check Squareness of Fold | 10 |
| 7.4 Use of Handwheel | 10 |
| 8.0 PERFORATING, SCORING & SLITTING | 10 |
| 8.1 Perforating | 10 |
| 8.2 Scoring | 11 |
| 8.3 Slitting | 11 |
| 9.0 MAINTENANCE | 12 |
| 9.1 Maintenance and Care of The Folder..... | 12 |
| 9.2 Lubrication | 12 |
| 9.3 Cleaning of Fold Rolls | 12 |
| 9.4 Cleaning Filters | 12 |
| 9.5 Photo Eyes | 12 |
| 9.6 Cleaning The Fold Stop Guides | 12 |

1.0 INTRODUCTION

Your new Air Feed Table Top Folder has been designed to give you many years of useful service provided it is installed, maintained, and operated according to the instruction in this manual.

The Folder is a unique and versatile paper folding machine, capable of folding paper measuring between 3 x 5 inches (7.6 x 12.7 cm) and 14 x 20 inches (35.3 x 50.8 cm), at speeds up to 35,000 sheets per hour of 8 1/2 x 11 (21.6 x 27.9 cm) and up to 65,000 sheets per hour of 3 x 5 inches (7.6 x 12.7 cm). The Folder will make six types of folds: single fold, letter fold, fan fold, French fold, double-parallel fold and a double letter fold, with a few simple settings. (Note: The French fold and double-letter fold requires either two passes or the use of a right-angle unit).

Your new folder is built rigid enough to ensure years of trouble-free performance, and at the same time, is compact enough to fit on any table or desk. It is portable so it can be moved anywhere it is needed.

2.0 SPECIFICATIONS

| | |
|-----------------------------------|---|
| Model No..... | 714XLT |
| Minimum Sheet Size | 3 x 5" (7.6 x 12.7 cm) |
| Maximum Sheet Size | 14 x 20" (35.5 x 50.8 cm) |
| Minimum Size Fold | 2 1/4" (5.7 cm) |
| Maximum Paper Weight | 65 lb. Cover |
| Stack Height | 2" (5.1 cm) |
| Fold Roll Speed | Infinitely variable between 0"/min. and 7200"/min. (18,288 cm/min. or 182 m/min.) |
| Fold Plate Depth | #1 Plate, 13.5" (34.3 cm) #2 Plate, 13.5" (34.3 cm) |
| Fold Roll Width | 14 1/8" (35.8 cm) |
| Fold Roll Diameter | 1 1/2" (3.8 cm) |
| Overall Physical Dimensions | Height 26" (66 cm) Length 34" (88 cm) Width 23 1/2" (60 cm) |
| Operating Voltage | DOM. 110 VAC/1PH/60Hz EXP. 220 VAC/1PH/60Hz |
| Power Consumption (folder) | 250 Watts |
| Power Consumption (pump) | 1500 Watts |
| Amperage (pump) | DOM. 13.6 Amp EXP. 6.8 Amp |

3.0 INSTALLATION

3.1 Unpacking & Inspection

The folder is packaged in three cartons, crated together as one package. It is broken down into 12 major assemblies for shipment. These are:

- A) Main Folder Assembly
- B) Pump Assembly
- C) Feed Table Assembly (not shown)
- D) Slitter Shaft Assembly
- E) Stacker Wheel Assembly
- F) Accessory Package (not shown)
- G) Fold Roll Guards (2)
- H) Stacker Tray
- I) Fold Pans (2)
- J) Hose Assembly (2)
- K) Literature Package (not shown)
- L) 1/2 Pint Surewash (not shown)

NOTICE

Immediately upon unpacking, carefully inspect each of the above assemblies for shipping damage. If any damage is found, be sure to contact the delivery freight carrier to file a damage claim. Save all packaging material for the claims adjustor to inspect.

WARNING

Do not plug the power cord into an AC outlet until The Folder is fully assembled, adjusted and ready to use. Unplug the Folder any time disassembly is required.

4.0 ASSEMBLY

4.1 Main Unit

To assemble the folder, first remove the four bolts holding it to the skid. Place the folder on the stand (see Figure 4.1-1).

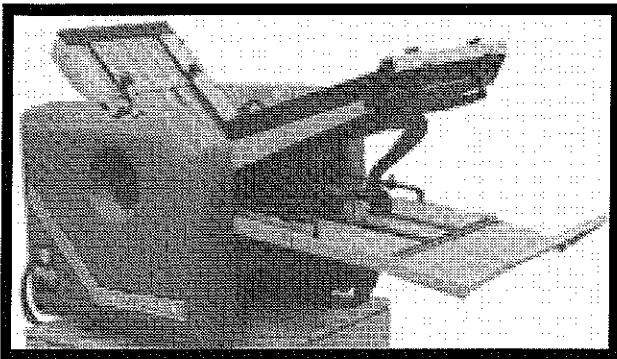

Figure 4.1-1

4.2 Pump Electrical Connections

The pump has a plug/cord set attached. This plug fits directly into the rear of the lefthand side cover. (See Figure 4.2-1)

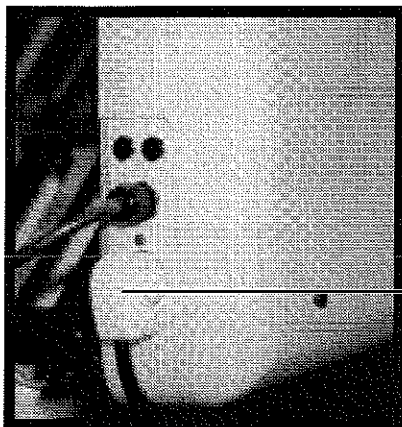

Figure 4.2-1

4.3 Pump Hose Connections

Two hoses come with your folder (see Figure 4.3-1).

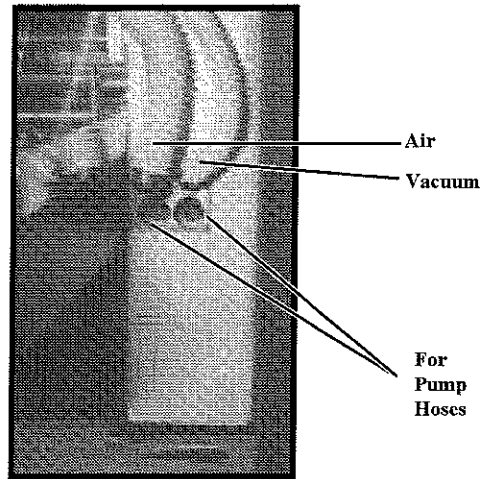

Figure 4.3-1

4.4 Slitter Shaft Installation

To install the slitter shaft, hold it with the grooves in the boxings down. Be sure the slitter shafts are free turning.

Insert the slitter shaft and seat the grooves in the boxings on the lower locating pins in the side frames. (See Figure 4.4-1)

Check for proper gear engagement between the upper slitter shaft gear and the 19-tooth frame idler gear by turning the handwheel.

Slitter Shaft Assembly



4.5 Delivery Table

To install the delivery table, loosen the knobs on either side of the stacker table. Drop the tray over the knobs and retighten.

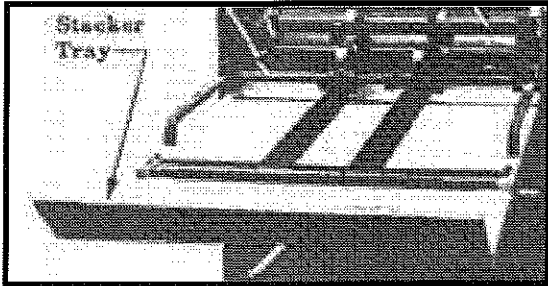

Figure 4.5-1

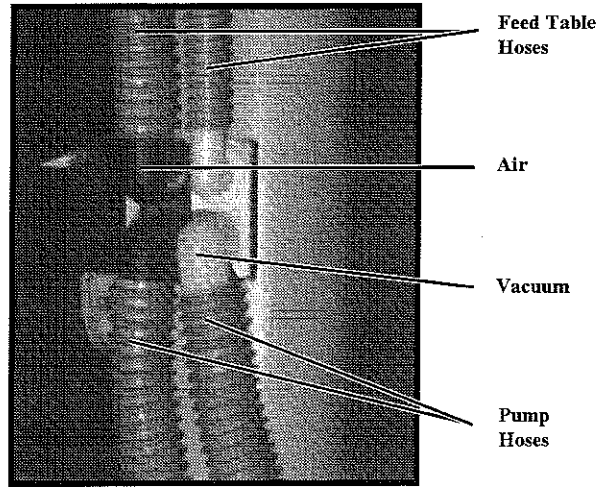

Figure 4.6-2

4.6 Feed Table Assembly Installation

Insert the feed table with the feed wheel toward the fold rolls. Slide the paper feed table over both sets of locating pins. (See Figure 4.6-1)

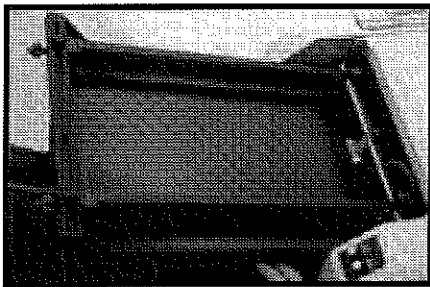

Figure 4.6-1

The first notch in the front part of the feed table should rest on the pins. Then drop the rear notch down on the upper dowel pins.

Rotate the handwheel to check that the gears are properly meshed.

Connect the feed table hoses. Push the fittings into the holes in the manifold block. (See Figure 4.6-2)

4.7 Fold Plate Installation

WARNING

Unplug the AC power cord when installing or removing fold plates.

The fold plates are marked #1 and #2 and are not interchangeable. The #1 fold plate is installed in the top position, the #2 fold plate in the lower position.

Each fold plate has an open end which faces toward the fold rolls.

To install the fold plates, pivot the fold plate hold-downs out of the way and slide the fold plate in position so that the slots in the leading edge of the fold plate engage the two locating pins in the side frames. (See Figure 4.7-1)

The center notches should seat on the second set of locating pins. Pivot the fold plate hold-downs back into position to secure the fold plates.

Turn the handwheel to be sure that the fold plates are properly installed and not rubbing on the fold rolls.

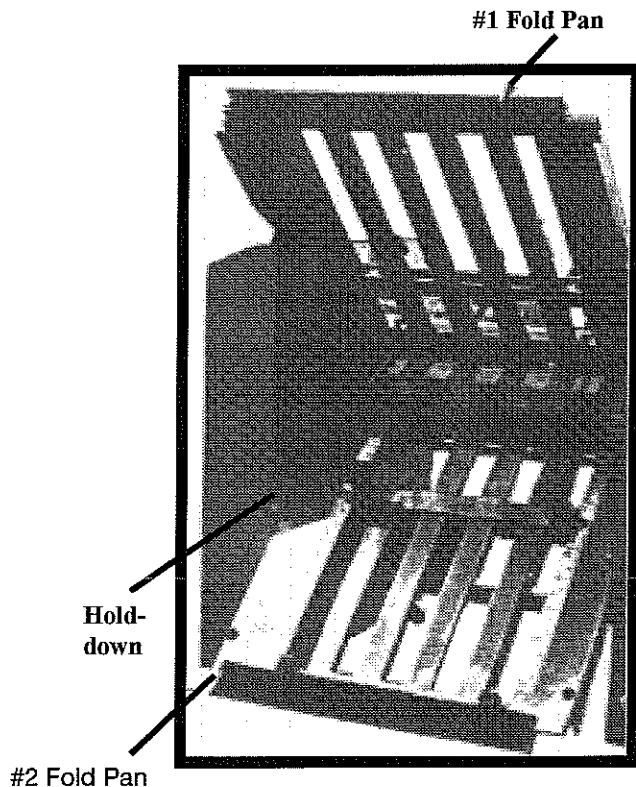

Figure 4.7-1

5.0 ELECTRICAL ACCESS

WARNING

Unplug the AC power cord before attempting any electrical repair.

The motor speed control and counter control are located under the left-hand side cover. The handwheel must be removed for access to these controls.

The cover can be removed by taking out the four screws located on the inside of the frame.

6.0 SETUP

6.1 Setting The Controls

The operator controls are conveniently located on a control panel on the left-hand side of The Folder.

These controls consist of an On/Off power switch, which is an overload reset, a speed control potentiometer, a pump On/Off switch, and a counter with zero reset.

Set these initially at:

- | | |
|------------------|--------------|
| A) Power Switch | Off position |
| B) Speed Control | "0" position |
| C) Pump Switch | Off position |
| D) Counter | "0" position |

6.2 Determining Paper Size and Type of Fold

The next step is to determine the paper size and type of fold to be made, following the steps below:

- Measure a sample sheet of the job to be run to determine its size. Retain this information for later use.
- Refer to the printed chart on the stacker tray (See Figure 6.2-1) and locate the type of fold that you want to make. (Example: letter fold)
- Locate on the chart the columns corresponding to the sheet size measured in Step A. (Example: 8 1/2x11)

| FOLDING CHART | TYPE OF FOLD | FOLD PLAN | SHEET SIZE | | | | | DEFLECTOR SETTING |
|--|----------------------|------------|------------|------------|------------|---------|---------|--|
| | | | 4 X 6 | 8 1/2 X 11 | 8 1/2 X 14 | 11 X 17 | 14 X 22 | |
| <small>BECAUSE THE PAPER SIZE & DIMENSIONS VARY, SMOOTH ADJUSTMENT OF THE PAPER STOPS MAY BE REQUIRED.</small> | LETTER FOLD | 1ST 2ND | C C | E E | H H | L L | H H | TWO FOLD POSITION |
| | PAN FOLD | 1ST 2ND | C C | E E | H H | L L | H H | TWO FOLD POSITION |
| | DOUBLE PARALLEL FOLD | 1ST 2ND | K A | K B | P G | T F | V J | TWO FOLD POSITION |
| | SINGLE FOLD | 1ST 2ND | — — | K — | P — | T — | V — | SINGLE FOLD POSITION |
| | FRENCH FOLD | 1ST 2ND | — — | K — | P — | T — | V — | SINGLE FOLD POSITION & ONE SCORING ROLLER |
| | DOUBLE LETTER FOLD | 1ST 2ND | — — | K — | P — | T — | V — | SINGLE FOLD POSITION & TWO SCORING ROLLERS |
| | ENGINEERING FOLD | 1ST 2ND | — — | — — | W B | V F | — — | TWO FOLD POSITION |

Figure 6.2-1

D) Locate the point on the chart where the columns for the type of fold and the sheet size intersect. You will notice that there are either two letters or a dash and a letter. These letters and/or dash tell you where to set the paper stop on the fold plate, and whether or not one of the fold plates will be installed in the deflector position.

Example #1 ; To make a letter fold to an 8 1/2 x11 sheet, set the paper stops for the #1 and #2 fold plates on the letter E. No dash appears, so neither fold plate is installed in the deflector position.

Example #2: To make a single fold to an 8 1/2x11 sheet, install the #2 fold plate in the deflector position. Set the paper stop for the #1 fold plate at the letter K.

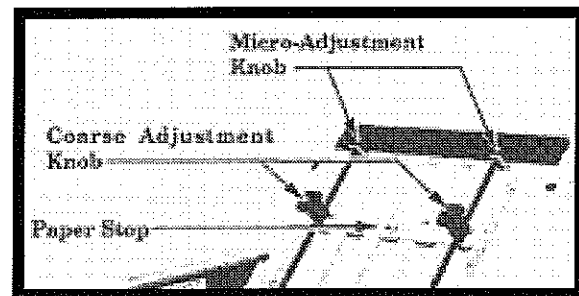

Figure 6.3-1

6.3 Paper Stop Adjustment

To move the paper stops to the correct position as determined in step #2, depress the coarse adjustment knobs on the paper stop and slide the paper stop until the indicating edge is aligned with the proper letter on the fold plate. (See Figure 6.3-1)

To obtain an exact setting on the paper stops, turn the micro-adjustment knobs until the indicating edge of the paper stop is perfectly aligned with the line adjacent to the letter on the plate.

6.4 Gap Adjustment

With the machine running, insert two sheets of paper between the tab and the sucker wheel. Turn the gap knob counterclockwise until there is a slight drag on the paper. Remove the paper. The correct gap is now set. (See Figure 6.4-1)

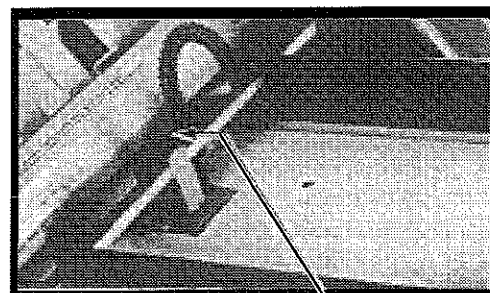

Gap Knob

Figure 6.4-1

6.5 Feed Table Adjustment

On the paper feed table there are two guides which keep the stack of paper properly aligned for feeding into the folder. Adjust these guides to correspond with the different widths of paper being fed. (See Figure 6.5-1)

To adjust the paper feed guides, loosen the two side guide locking knobs on each guide. Slide the guides from side to side until the inside edge of each guide is aligned with the number corresponding to the width of the paper being folded.

Example: For an 8 1/2-in wide sheet, move the side guides until the inside edges align with the "8 1/2" on the feed table.

An additional check is to lay a sheet of paper on the feeder, close to but not touching the side guides. Push the sheet down into the nip of the fold rolls. Then align the guide by loosening the adjusting knobs and aligning the guide so that it is parallel to the edge of the paper. When one side is square, the other side can be moved into position.

Tighten the locking knobs to secure the paper guides in position.

When you load the actual job, you may have to move these guides slightly to take care of variations in sheet size. To feed properly, the paper must slide freely between these guides.

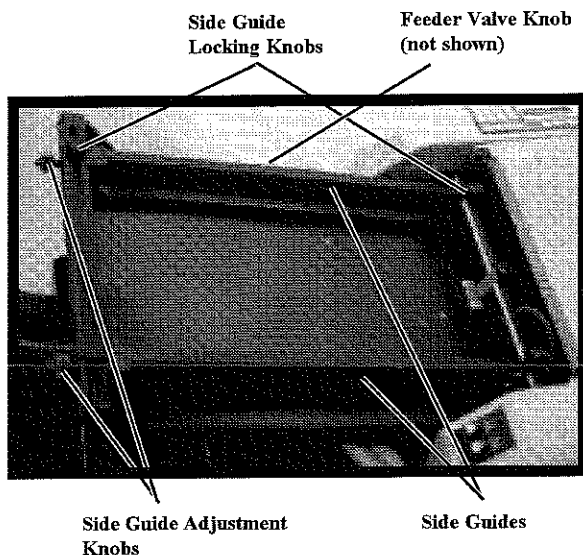

Figure 6.5-1

6.6 Air Blow Adjustment

Turn the air blow adjustment on the vacuum/air control panel fully counterclockwise to the + position. Except for when very small sheets are being run, the air blow adjustment is left adjusted for maximum air. (See Figure 6.6-1)

Once the amount of air blow has been selected using the air blow adjustment, the feeder valve knob may be used to direct the air (See Figure 6.5-1).

Turn the knob to the right to obtain more blow on the right side and front of the feed table. Turn the knob to the left to obtain more blow on the left side and lessen the front blow.

Turn the vacuum adjustment clockwise all the way down. This setting is used for most light and medium papers. Heavy paper will require more vacuum.

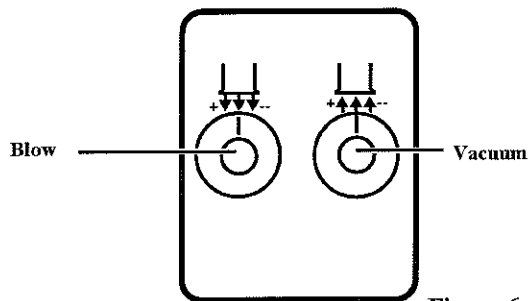

Figure 6.6-1

7.0 OPERATION

7.1 Loading of Feed Table

Before you can load the paper on the feed table, you must determine which way the paper is to be loaded by running a few sample sheets. (Example: printing face up or face down)

Then you can load a stack of paper no higher than two inches between the paper feed guides. Let the stack slide freely down into position between the side guides.

7.2 Starting the Vacuum/Air Feeder

After the vacuum and air adjustments have been made, start the folder, then start the vacuum/pump.

Additional paper can be loaded on top of the stack of paper already in the feeder without stopping the machine.

If the feeder runs out of paper or if you want to stop the machine for any reason, first turn off the vacuum pump, then the folder.

7.3 Check Squareness of Fold

Examine the folded sheets on the stacker to make sure that you are getting an even and square fold.

There is a skew adjustment on each plate to adjust for a square fold on paper that is not cut square (See figure 4.7-1).

7.4 Use of Handwheel

The handwheel is used to help clear jams and for setup. To use the handwheel, shut off the folder, pull out the handwheel and turn it in either direction.

8.0 PERFORATING, SCORING & SLITTING

In addition to folding, your Folder can perforate, score and slit.

WARNING

Be careful when handling perforator and slitting blades. They are extremely sharp.

8.1 Perforating

The Folder can be used to perforate either the folded sheet (to assist in making a right-angle fold) or to perforate sheets delivered flat. The Folder comes with one standard 41-tooth perforator blade. Additional perforator blades are available through the Parts Department.

The perforator blade should be mounted loosely to the blade holder with the retainer collar to give better support to the perforator blade. Always be sure that the flat side of the blade is against the blade holder. Loosen the brass-tipped set screws in the perforator collar and blade holder before attempting to place them on the slitter shafts.

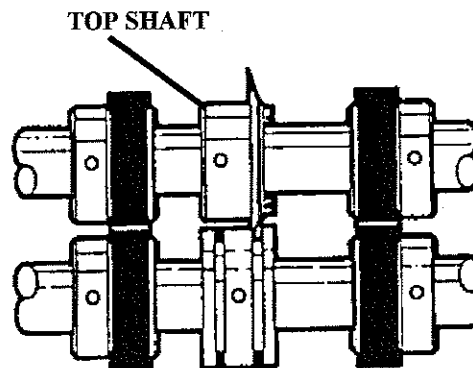

Figure 8.1-1

The perforating blade holder assembly is then slid onto the upper slitter shaft along with the necessary pull-out tire assemblies. Then tighten the screws holding the perforator blade to the blade holder, aligning the blade to the holder. This allows for free horizontal movement on the shaft.

Slide the grooved perforator collar onto the lower slitter shaft along with the other pull-out tire assemblies. The flat side of the perforator blade should just touch the side of the groove in the perforator collar. (See Figure 8.1-1)

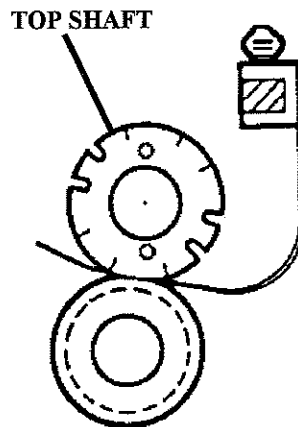

Figure 8.1-2

Slide the perforator collar and blade holder to the desired position on the slitter shaft. Then lock the blade holder and perforator collar into position with the brass-tipped set screw.

The perforator stripper fits onto the slitter shaft bar in between or next to the perforating blade. (See Figure 8.1-2) This strips the paper off for delivery and prevents it from wrapping around the perforator blade.

8.2 Scoring

The Folder can be used to score a sheet and deliver it flat, or to score a sheet after a fold or folds have been made.

To ensure accuracy in making right-angle folds, always score the sheet where the fold is to be made. This applies in all instances when a perforator cannot be used.

Attach the scoring blade loosely to the blade holder for mounting on the slitter shaft. Scoring blades can be mounted on either the upper or lower slitter shaft. Once on the shaft, tighten the screws, aligning both the blade and the collar. This allows free horizontal movement on the shaft. Scoring blades should be placed so that the fold will be made with rather than against the scoring, or, in a continuing direction to the pressure of the crease that has been applied by the scoring blade.

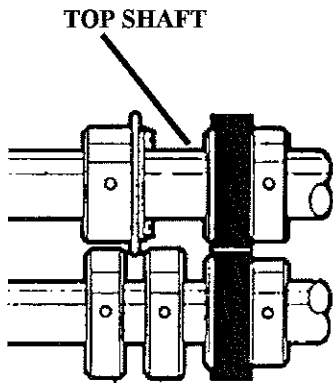

Figure 8.2-1

For a wide, well-rounded score, use the two steel scoring collars. (See Figure 8.2-1) Sharpness and the depth of the score can be controlled by regulating the distance the collars are placed away from the scoring blade.

The scoring collars can also be placed on either side of the rubber scoring collar. The two collars can be compressed against the rubber collar, causing the rubber to bulge up for a deeper score. (See Figure 8.2-2)

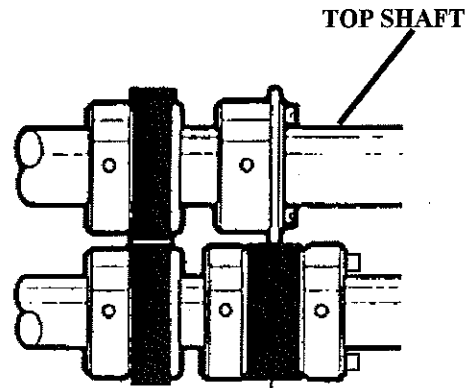

Figure 8.2-2

8.3 Slitting

NOTE: Slitting accessories are optional on your Folder and can be ordered from the Parts Department.

The Folder can be used to cut folded or flat sheets apart. The general setup for blades and collars is shown in (Figure 8.3.1). Two or more cuts may be made if duplicate sets of cutters are used.

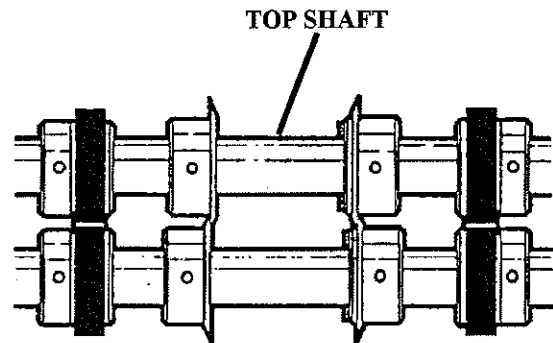

Figure 8.3.-1

Use care in mounting slitter blades to the collars in order to avoid ragged edges during slitting operations. Ragged edges can be caused by two conditions:

- 1) Nicks or burrs on the collars or blades. Remove carefully by filing or using a fine piece of emery cloth.
- 2) Incorrect mounting of blades caused by tightening with the wrong type of screw. Always use flat head screws on the side of the blade and blade holder collar, which are countersunk.

Before tightening the blade to the collar, slide the blade with the collar loosely attached on the end of the shaft. Then tighten securely, thus aligning both the blade and collar, allowing free horizontal movement along the shaft.

Place the blade, mounted on the collar, on the upper shaft in the proper position where the cut is to be made. Then move the blade and collar on the lower shaft so that the two flat edges of the blades are pressed snugly together. Too much space between the blades will produce a ragged cut.

Space the rubber pull-out tires to support the sheet.

9.0 MAINTENANCE

9.1 Maintenance and Care of your Folder

The Folder has been designed to give you years of useful service, provided you maintain it according to these instructions.

9.2 Lubrication

Apply one or two drops of light machine oil at all slitter shaft bearings and the feed table bearings and idler gear once a week. Be sure to keep oil off any surface which may contact the paper.

9.3 Cleaning of Fold Rolls

Periodically wipe off the rubber surface of the fold rolls using an approved solvent such as Surewash or its equivalent. Surewash is available from the Parts Department in 1-quart and 1-gallon containers. A complementary bottle of Surewash is included with your machine.

9.4 Cleaning Filters

The filters on the pump should be checked periodically and cleaned as needed. The filters can be reached by unscrewing the filter jars.

9.5 Photo Eyes

Occasionally wipe off the photo eye with a dry cloth.

9.6 Cleaning The Fold Stop Guides

The fold stop guides (See figure 4.7-1) should be cleaned once a week with a dry cloth to keep the plate moving properly.

We Have it All...



MyBinding.com

When Image Matters.

Guaranteed Lowest Prices on an
Endless Selection of Binding Systems, Laminators,
Paper Shredders, Supplies and Accessories.

We have you covered with Expert Advice
and Support. Our popular blog keeps you up to
date on the latest tips and techniques to make
your most important binding and laminating
tasks a success.

Call Us Today

1-800-944-4573

Our Trusted Partners

GBC / Ibico
Fellowes
Powis Fastback
Unibind
Akiles
Renz
Tamerica
Rhin-O-Tuff
DFG

Pro-Bind
Martin Yale
MBM
Formax
Intimus
Dahle
HSM
Standard
Xyron

Challenge
Lasko-Wizer
GBC Shredmaster
Avery
Wilson Jones
Cardinal
Samsill
Universal

- BINDING MACHINES
- BINDING SUPPLIES
- LAMINATORS
- I.D. ACCESSORIES
- BOARDS & EASELS
- PAPER SHREDDERS
- XYRON LAMINATORS
- COIL BINDING MACHINES
- UNIBIND BINDING MACHINES
- FASTBACK BINDING EQUIPMENT
- PAPER FOLDING MACHINES
- LAMINATING POUCHES
- ROTARY TRIMMERS
- CLEAR COVERS
- TWIN LOOP WIRE
- REGENCY COVERS
- PLASTIC BINDING COVERS
- VELOBIND BINDING MACHINES
- PAPER HANDLING EQUIPMENT
- THERMAL BINDING MACHINES
- PROCLICK BINDING SYSTEMS
- COMB BINDING MACHINES
- COMB BINDING SUPPLIES
- WIRE BINDING MACHINES
- POUCH LAMINATORS
- LAMINATING ROLLS
- 3-RING BINDERS
- ROLL LAMINATORS
- VELOBIND SPINES
- PAPER CUTTERS
- PAPER JOGGERS
- LETTER OPENERS
- THERMAL COVERS
- UNIBIND SUPPLIES
- PROCLICK SPINES
- ZIPBIND SPINES
- LINEN COVERS
- SPIRAL COIL
- INDEX TABS

