

Fellowes DS-2 PS 2007 Shredder

Instruction Manual



Provided By

MyBinding.com
When Image Matters.

Australia
Canada
México
United States

Help Line

+ 1-800-33-11-77
+ 1-800-665-4339
+ 1-800-234-1185
+ 1-800-955-0959

Australia
Benelux
Canada
Deutschland
France
Italia
Japan
Korea
Malaysia
Polska
España
Singapore
United Kingdom
United States

Fellowes

+ 61-3-8336-9700
+ 31-(0)-76-523-2090
+ 1-905-475-6320
+ 49-(0)-5131-49770
+ 33-(0)-1-30-06-86-80
+ 39-071-730041
+ 81-(0)-3-5496-2401
+ 82-2-3462-2884
+ 60-(0)-35122-1231
+ 48-(0)-22-771-47-40
+ 34-91-748-05-01
+ 65-6221-3811
+ 44-(0)-1302-836836
+ 1-630-893-1600

www.fellowes.com

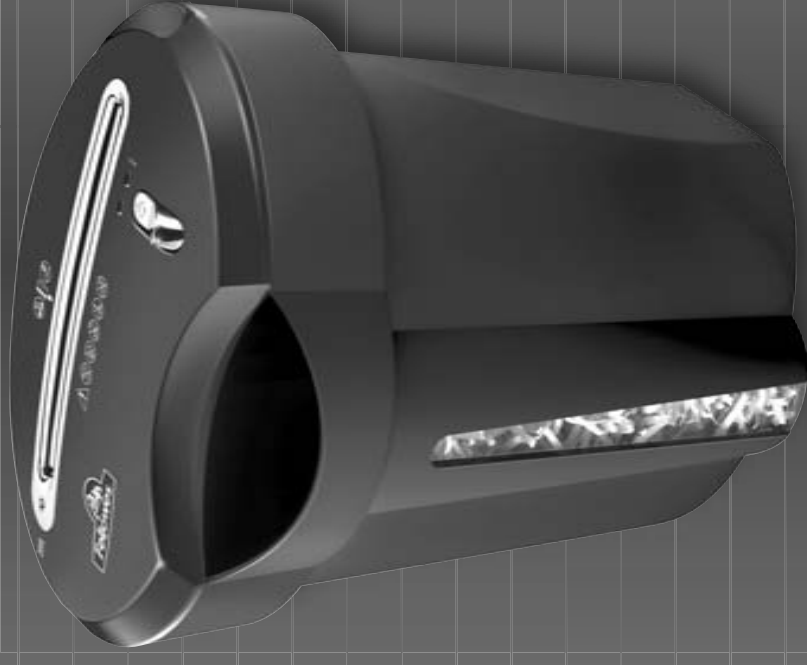

DS-2

Please read these instructions before use.



Fellowes 1789 Norwood Avenue, Itasca, Illinois 60143-1095 • USA • 630-893-1600 <http://www.fellowes.com>

Australia Benelux	Canada China	Deutschland España	France Italia	Japan Korea	Polska Singapore	United Kingdom United States
----------------------	-----------------	-----------------------	------------------	----------------	---------------------	---------------------------------

© 2007 Fellowes, Inc. Part No. 402338

ENGLISH

Model DS-2

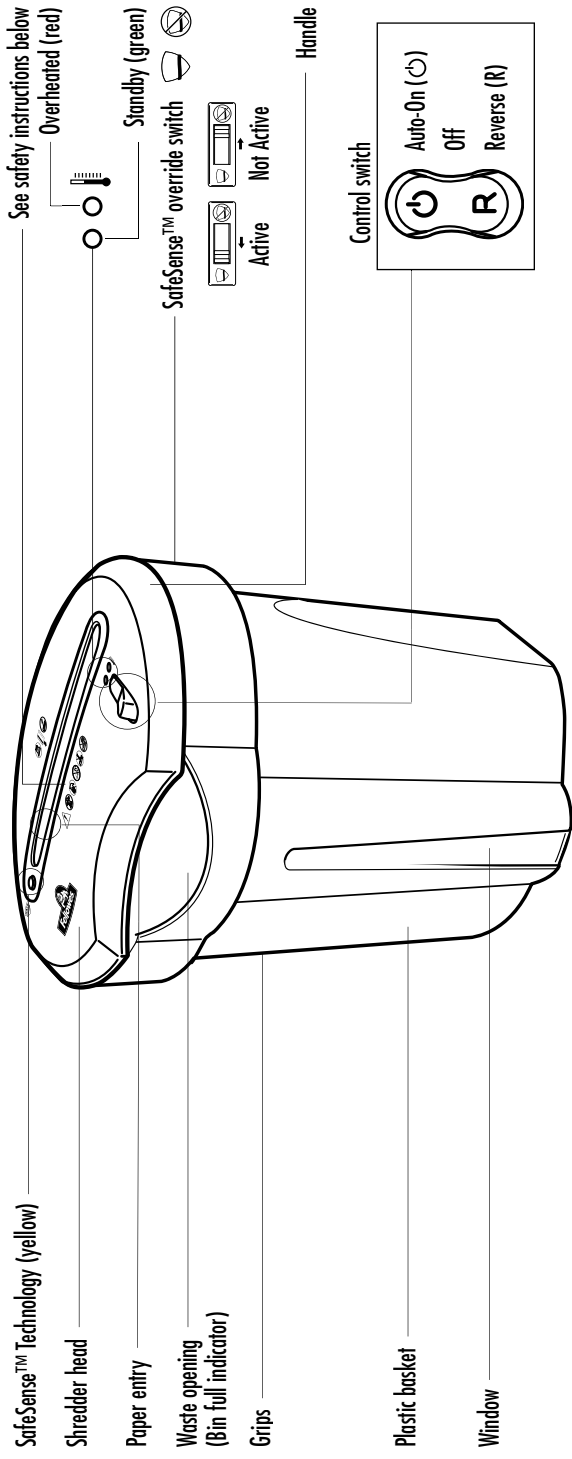

See safety instructions below

- Overheated (red)
- Standby (green)
- SafeSense™ override switch
- Active
- Not Active

SAFE Breakthrough Safety Technology! SafeSense™ stops shredding when hands are too close to the opening.

SET-UP

— To Test SafeSense™ Technology

Place head on basket as shown:

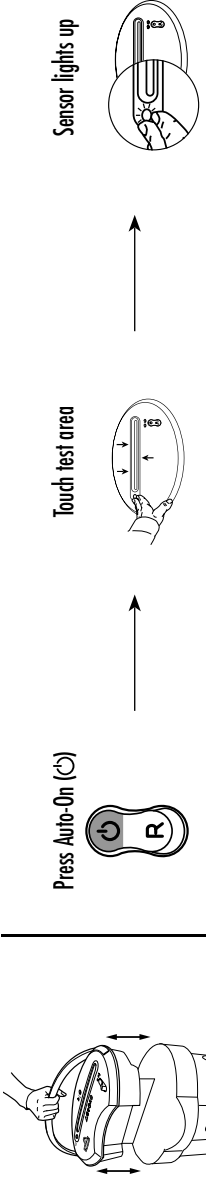

CAPABILITIES

Will shred: Paper, small paper clips, credit cards and staples

Will not shred: Continuous forms, adhesive labels, transparencies, newspaper, cardboard, large paper clips, laminates or plastic other than noted above

Paper shred size: Confetti-Cut 5/32" x 2" (3.9 x 50mm)

Maximum:

Sheets per pass (Confetti-Cut)	8*
Cards per pass	1
Passes per day	10-20
Paper width	9" / 229mm
Continuous operation	2-4 minutes

*20 lb., 8.5" x 11" paper at 120v, 60 Hz, 3.5 Amps; heavier paper, humidity or other than rated voltage may reduce capacity.

IMPORTANT SAFETY INSTRUCTIONS — Read Before Using!

WARNING

- Keep away from children and pets. Keep hands away from paper entry. Always unplug when not in use.
- Keep foreign objects – gloves, jewelry, clothing, hair, etc. – away from shredder openings. If object enters top opening, press and hold Reverse (R) to back out object.

CAUTION

- Avoid touching exposed blades under Confetti-Cut shredder head.
- The socket-outlet shall be installed near the equipment and shall be easily accessible.

OPERATION



Continuous operation:

2-4-minute maximum
NOTE: Shredder runs briefly after each pass to clear entry. Continuous operation beyond 2-4-minutes will trigger 1-5-minute cool down period.

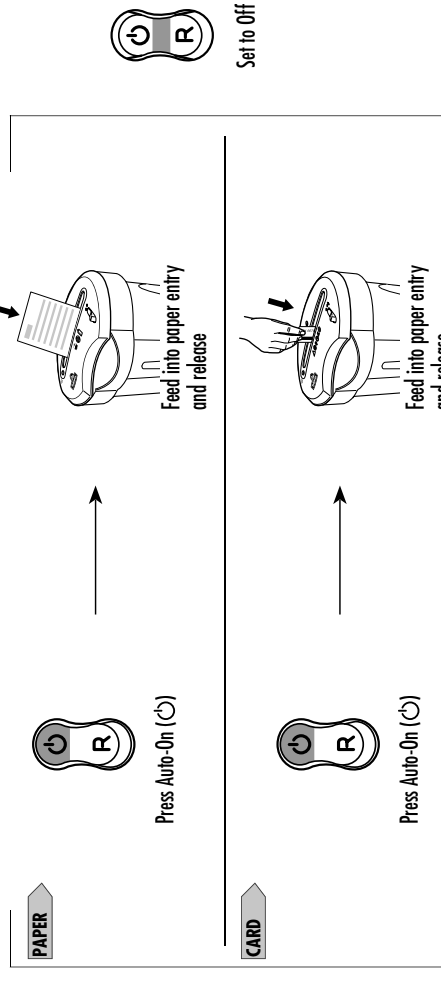

TROUBLESHOOTING

Paper jam: Set to Off (O), remove shredder head and empty bin. Replace shredder head, and follow any or all of the below procedures.

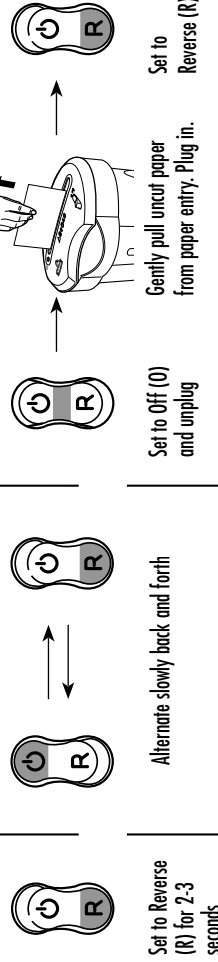

Shredder doesn't start:

- Yellow - SafeSense™ active
- Yellow flashing - SafeSense™ not active. Make sure head is on basket correctly. Wait 15 minutes for motor to cool down. Remove and empty basket.

ATTENTION: If the SafeSense™ light remains on, you must engage the **Override Switch** in order to perform steps above. Once the jam is cleared, reset the SafeSense™ feature. (See SafeSense™ instructions below.)

SAFE **SafeSense™ paper jam:** If the SafeSense™ feature activates (SafeSense™ light remains on) to cause the user to think the shredder has jammed when it has not, use the **Override Switch** to deactivate the SafeSense™ feature and clear the paper. **Warning** – when switch is in override position, the SafeSense™ light will flash and the SafeSense™ feature will NOT function. Once the paper is cleared, reset the SafeSense™ feature.



MAINTENANCE

Run regularly in reverse for one minute

- Oil when bin is full, or immediately, if:
 - Capacity decreases
 - Motor sounds different, or
 - Shredder stops running

Follow oiling procedure below and repeat twice.

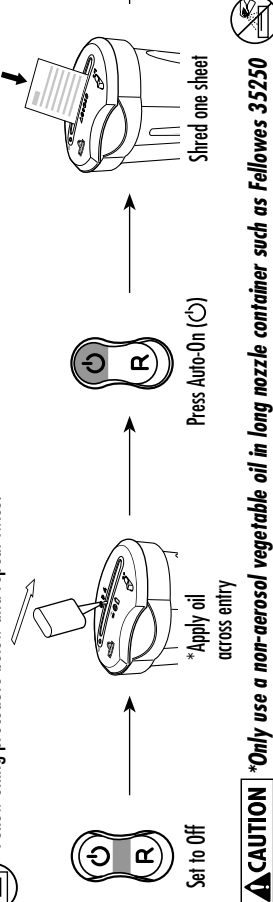

CAUTION *Only use a non-aerosol vegetable oil in long nozzle container such as Fellowes 35250

WARRANTY

LIMITED WARRANTY Fellowes, Inc. ("Fellowes") warrants the cutting blades of the machine to be free from defects in material and workmanship for 5 years from the date of purchase by the original consumer. Fellowes warrants all other parts of the machine to be free of defects in material and workmanship for 1 year from the date of purchase by the original consumer. If any part is found to be defective during the warranty period, your sole and exclusive remedy will be repair or replacement, at Fellowes' option and expense, of the defective part. This warranty does not apply in cases of abuse, mishandling, or unauthorized repair. ANY IMPLIED

WARRANTY, INCLUDING THAT OF MERCHANTABILITY OR FITNESS FOR A PARTICULAR PURPOSE, IS HEREBY LIMITED IN DURATION TO THE APPROPRIATE WARRANTY PERIOD SET FORTH ABOVE. In no event shall Fellowes be liable for any consequential or incidental damages attributable to this product. This warranty gives you specific legal rights. The duration, terms, and conditions of this warranty are valid worldwide, except where different limitations, restrictions, or conditions may be required by local law. For more details or to obtain service under this warranty, please contact us or your dealer.

We Have it All...



MyBinding.com *When Image Matters.*

Guaranteed Lowest Prices on an
Endless Selection of Binding Systems, Laminators,
Paper Shredders, Supplies and Accessories.

We have you covered with Expert Advice
and Support. Our popular blog keeps you up to
date on the latest tips and techniques to make
your most important binding and laminating
tasks a success.

Call Us Today

1-800-944-4573

Our Trusted Partners

GBC / Ibico
Fellowes
Powis Fastback
Unibind
Akiles
Renz
Tamerica
Rhin-O-Tuff
DFG

Pro-Bind
Martin Yale
MBM
Formax
Intimus
Dahle
HSM
Standard
Xyron

Challenge
Lasko-Wizer
GBC Shredmaster
Avery
Wilson Jones
Cardinal
Samsill
Universal

- BINDING MACHINES
- BINDING SUPPLIES
- LAMINATORS
- I.D. ACCESSORIES
- BOARDS & EASELS
- PAPER SHREDDERS
- XYRON LAMINATORS
- COIL BINDING MACHINES
- UNIBIND BINDING MACHINES
- FASTBACK BINDING EQUIPMENT
- PAPER FOLDING MACHINES
- LAMINATING POUCHES
- ROTARY TRIMMERS
- CLEAR COVERS
- TWIN LOOP WIRE
- REGENCY COVERS
- PLASTIC BINDING COVERS
- VELOBIND BINDING MACHINES
- PAPER HANDLING EQUIPMENT
- THERMAL BINDING MACHINES
- PROCLICK BINDING SYSTEMS
- COMB BINDING MACHINES
- COMB BINDING SUPPLIES
- WIRE BINDING MACHINES
- POUCH LAMINATORS
- LAMINATING ROLLS
- 3-RING BINDERS
- ROLL LAMINATORS
- VELOBIND SPINES
- PAPER CUTTERS
- PAPER JOGGERS
- LETTER OPENERS
- THERMAL COVERS
- UNIBIND SUPPLIES
- PROCLICK SPINES
- ZIPBIND SPINES
- LINEN COVERS
- SPIRAL COIL
- INDEX TABS

