

# DAHLE 20434DS DEPLOYMENT SHREDDER

## Instruction Manual



Provided By

**MyBinding.com**  
*When Image Matters.*

# Deployment Shredder

## 20434 DS

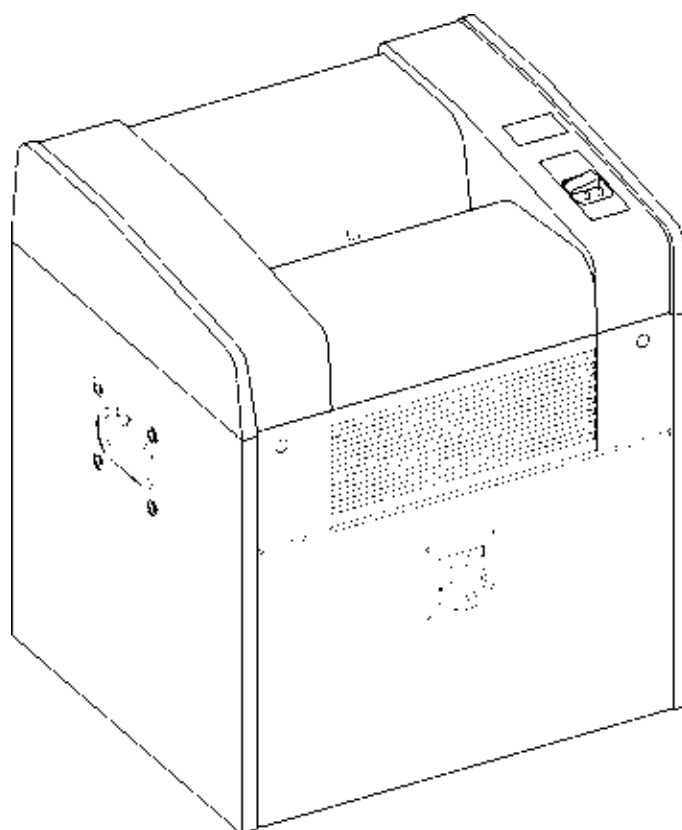

**OPERATION MANUAL**  
20434.90.0182 – 02/05-

## **Congratulations** on your purchase of a DAHLE 20434 Deployment Shredder!

We here at DAHLE North America are dedicated to providing rugged and dependable products for the large, and not so large office. We are sure your new DAHLE 20434 Deployment Shredder will meet or exceed your expectations of quality and service.

If you have any questions regarding your new DAHLE paper shredder, call your sales representative, or call DAHLE N.A. Customer Service, toll free, at (800) 995-1379 between 8:30 am and 5:00 pm Monday through Friday, EST.

Record the serial number for your records in the space provided below.

20434 DS

Serial Number: \_\_\_\_\_

## **DIAGRAM KEY**

---

1. Feed Opening
2. Light Barrier
3. On/Off/Reverse
4. Warning LED indicator (Drawer full, Drawer ajar)
5. Power Light
6. Transport Bolts
7. Drawer pull
8. Drawer

**READ ALL INSTRUCTIONS BEFORE OPERATING YOUR SHREDDER**



When Image Matters.

## SAFETY INSTRUCTIONS

---



- Read the operating instructions carefully before operating your shredder!
- Do not use in the vicinity of flammable liquids or gases.
- Do not use in the vicinity of corrosive materials.
- Do not expose to water or wet conditions.
- Do not let children operate this, or any other, office equipment.
- Do not reach into the cutting mechanism during operation – not even from the top or with objects.
- Do not operate the shredder for a period of more than 5 minutes in no-load operation (operation without paper).
- Keep hair clear of machine.
- Keep neckties clear of machine.
- Keep bracelets, or any other jewelry, clear of machine.
- Power connection must be accessible at all times.
- Disconnect from power supply before servicing.
- The safety devices must not be disabled or removed.



## BEFORE YOU SHRED

---

Remove Transport Bolts (6) with wrench provided.

- Read all instructions carefully.
- Record the Serial Number in the space provided inside the front cover.
- Be sure the electrical outlet provides the proper power for your shredder (see rating label on rear of shredder).

**ALWAYS TURN SHREDDER OFF IF IT WILL BE UNATTENDED FOR LONG PERIODS OF TIME**



When Image Matters

## TURNING ON YOUR SHREDDER

---

- ① ON, OFF and REVERSE are controlled by the black Rocker Switch (3) on the top of the shredder.
- ② Moving the switch to the “I” (ON) position places the shredder in the standby mode.  
*Note: Shredder will run momentarily.*
- ③ Moving the switch to the center or “O” (OFF) position turns the shredder off.
- ④ The REVERSE position “R” will be discussed in “CLEARING A PAPER JAM”.

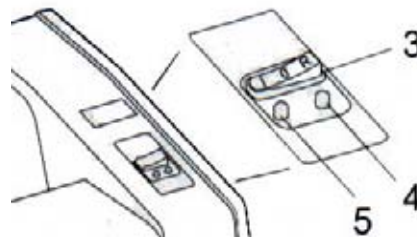

## SHREDDING

---

Turn shredder on. Insert paper squarely into Feed Opening (1). A light barrier (2) will automatically activate the shredding mechanism. Continue feeding paper into the Feed Opening until the shredding mechanism begins to draw the paper in. At this point, allow the paper to feed into the shredder on its own. Once the paper has passed completely through the shredding mechanism, the electronic controls will automatically stop the machine.

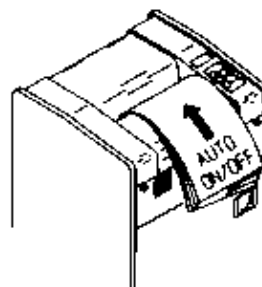

Microfiche and transparencies can also be shredded in the same manner as paper. However, you should shred a piece of paper after every 8 or 10 sheets of plastic. This helps clean plastic particles out of the shredding mechanism.

**ALWAYS TURN SHREDDER OFF IF IT WILL BE UNATTENDED FOR LONG PERIODS OF TIME**



When Image Matters

## CAPACITY

---

Capacity is the number of sheets of 8½" x 11" paper that can be shredded at one time. These figures are approximate and machines may vary slightly due to various conditions. It is not recommended that you try to run your shredder at maximum capacity, as this increases the chance of a paper jam.

<u>Model</u>	<u>20 Lb. Bond</u>	<u>16 Lb. Bond</u>
20434 DS	4	6

## EMPTYING THE DRAWER

---

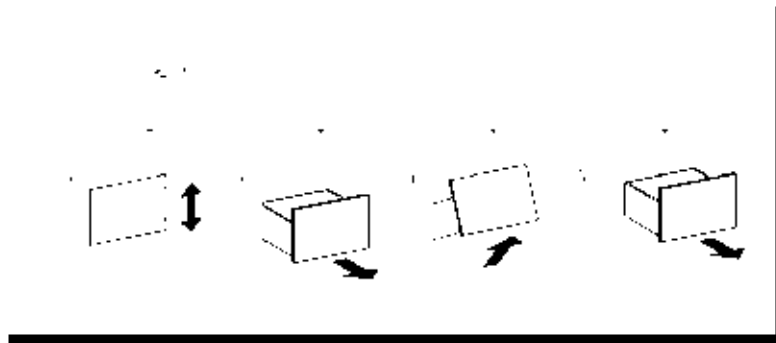

When the drawer (8) is full, the shredder will automatically shut off. The electronics will cause the amber Warning LED Indicator to light. Emptying the drawer is quick and easy if you follow these simple directions.

- ① Turn shredder off
- ② Shake the drawer (8) several times using the grip (7).
- ③ Pull out the drawer carefully of the cabinet till you notice a limit stop and then lift it upward out of the stracks.
- ④ Empty the drawer.
- ⑤ Re-install the emptied drawer back into the cabinet in reverse order.
- ⑥ Turn on shredder and continue shredding.

IT IS NOT RECOOEND RUNNING SHREDDERS AT MAXIMUM CAOACITY



When Image Matters

## CARING FOR YOUR SHREDDER

---

**Clean covers with a clean dry cloth. Do not use water or solvents. Make sure you disconnect your shredder from its power source before cleaning.**

Paper shredders, like all mechanical equipment, need proper maintenance to ensure efficient operation. Periodic lubrication of the cutting blades is important to offset the friction generated within the cutting head. Frequency of lubrication will vary depending on the shred size and the amount of usage. A strip-cut shredder receiving light use (*1 – 2 hours per week*) will require lubrication only once or twice a month, while the same machine used 1 – 2 hours per day will require lubrication weekly. A cross-cut shredder should be lubricated every  $\frac{1}{2}$  hour of shredding time to maintain maximum capacity and efficiency.

**The procedure for lubricating your shredder is simple, and can be performed by any operator. The oil is packaged in a squeeze bottle and is applied directly to the cutting blades through the feed opening (3). Run a fine stream of lubricant from one side of the feed opening to the other. Run the shredder in REVERSE for a few seconds to help distribute the lubricant evenly. You can now continue shredding as usual.**

**DAHLE Shredder Oil is the only lubricant you should use in your shredder. It has been specially formulated so as not to leave any residue that could attract dust and clog the shredding mechanism. You can order DAHLE Shredder Oil (item # 740) from your local dealer or by calling Dahle North America, Inc. at (800) 995-1379.**

Repairs on your paper shredder should only be performed by qualified technicians. ***If you need service***, contact your local dealer, or you can contact DAHLE North America Customer Service between 8:30 am and 5:00 pm EST at (800) 995-1379.

## CLEARING A PAPER JAM

---

If too many sheets of paper are fed into your shredder at one time, it may cause a paper jam. Running your shredder at maximum capacity increases the chance of a paper jam. If a paper jam occurs, it is easy to clear by following these simple steps:

- ① Turn shredder off using ON/OFF/REVERSE switch (3)
- ② Firmly pull on paper sticking out of Feed Opening while holding ON/OFF/REVERSE switch in the REVERSE (R) position.
- ③ After paper has been removed from the Feed Opening, move the ON/OFF/REVERSE switch back to the ON (I) position.
- ④ Separate some of the sheets and continue shredding.

**NOTE: SHREDDER WILL NOT OPERATE UNLESS DRAWER IS COMPLETELY CLOSED**



## BEFORE YOU CALL FOR SERVICE

---

<b>SYMPTOM</b>	<b>POSSIBLE CAUSES</b>	<b>SOLUTION</b>
No Power	<ul style="list-style-type: none"><li>❶ ON/OFF Switch set to wrong position</li><li>❷ Unit unplugged</li><li>❸ Outlet dead</li><li>❹ Drawer not fully closed</li><li>❺ Drawer full</li></ul>	<p>Move Switch to "I" (on) position. Connect to outlet Reset circuit breaker</p> <p>Close drawer Empty drawer</p>
Low capacity	<ul style="list-style-type: none"><li>❶ Cutting blades dry</li></ul>	<p>Lubricate cutting blades according to instructions.</p>

## DAHLE SHREDDER SUPPLIES AND ACCESSORIES

---

### Shredder Oil (*All Models*)

740

Box of 4 - 16oz. Bottles

740G

Box of 4 - 1gal Bottles





**Dahle North America, Inc.**

375 Jaffrey Road

Peterborough, NH 03458

Tel: (603) 924-0003 • Fax: (603) 924-1616

Email: shredders@dahle.com

**w w w . d a h l e . c o m**



# We Have it All...



## **MyBinding.com** *When Image Matters.*

**Guaranteed Lowest Prices** on an  
Endless Selection of Binding Systems, Laminators,  
Paper Shredders, Supplies and Accessories.

**We have you covered** with Expert Advice  
and Support. Our popular blog keeps you up to  
date on the latest tips and techniques to make  
your most important binding and laminating  
tasks a success.

**Call Us Today**

**1-800-944-4573**

### **Our Trusted Partners**

GBC / Ibico  
Fellowes  
Powis Fastback  
Unibind  
Akiles  
Renz  
Tamerica  
Rhin-O-Tuff  
DFG

Pro-Bind  
Martin Yale  
MBM  
Formax  
Intimus  
Dahle  
HSM  
Standard  
Xyron

Challenge  
Lasko-Wizer  
GBC Shredmaster  
Avery  
Wilson Jones  
Cardinal  
Samsill  
Universal

- BINDING MACHINES
- BINDING SUPPLIES
- LAMINATORS
- I.D. ACCESSORIES
- BOARDS & EASELS
- PAPER SHREDDERS
- XYRON LAMINATORS
- COIL BINDING MACHINES
- UNIBIND BINDING MACHINES
- FASTBACK BINDING EQUIPMENT
- PAPER FOLDING MACHINES
- LAMINATING POUCHES
- ROTARY TRIMMERS
- CLEAR COVERS
- TWIN LOOP WIRE
- REGENCY COVERS
- PLASTIC BINDING COVERS
- VELOBIND BINDING MACHINES
- PAPER HANDLING EQUIPMENT
- THERMAL BINDING MACHINES
- PROCLICK BINDING SYSTEMS
- COMB BINDING MACHINES
- COMB BINDING SUPPLIES
- WIRE BINDING MACHINES
- POUCH LAMINATORS
- LAMINATING ROLLS
- 3-RING BINDERS
- ROLL LAMINATORS
- VELOBIND SPINES
- PAPER CUTTERS
- PAPER JOGGERS
- LETTER OPENERS
- THERMAL COVERS
- UNIBIND SUPPLIES
- PROCLICK SPINES
- ZIPBIND SPINES
- LINEN COVERS
- SPIRAL COIL
- INDEX TABS

