

AKILES WIREMAC DUO

Instruction Manual



Provided By

MyBinding.com®
When Image Matters.

WIREMAC DUO OPERATION MANUAL

INTRODUCTION

CONGRATULATIONS ON THE PURCHASE OF YOUR NEW WIREMAC DUO, A PROFESSIONAL AND HEAVY-DUTY WIRE PUNCH AND BINDING MACHINE. YOUR DUAL TWIN BINDER WAS DESIGNED WITH A FULL RANGE OF FUNCTION AND PREMIUM QUALITY COMPONENTS TO GUARANTEE YOU AN EFFORTLESS AND PROFESSIONAL BIND, AS WELL AS MANY YEARS OF TROUBLE-FREE SERVICE.

IMPORTANT

WE RECOMMEND THAT YOU TAKE A FEW MINUTES TO FAMILIARIZE YOURSELF WITH THE FUNCTIONS OF YOUR NEW WIREMAC DUO. YOU WILL FIND THAT WITH JUST A LITTLE PRACTICE, ANY PERSON CAN ACHIEVE PROFESSIONAL RESULTS.

FEATURES

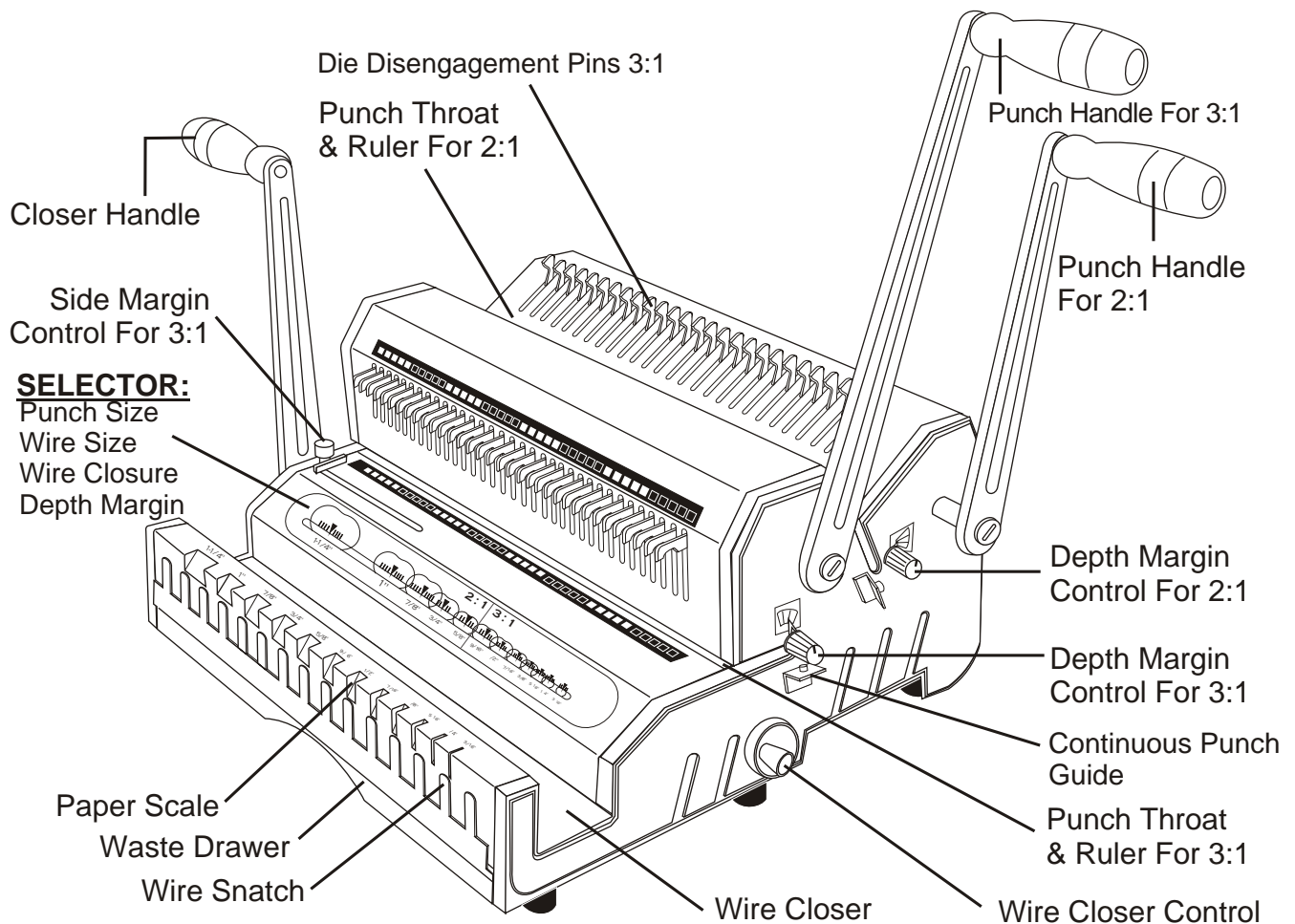

ASSEMBLY

1. Place your new WireMac DUO on top of a sturdy working table.
2. Remove The Screw from Punching Axle clockwise as indicated, connect 2 Punch Handles, the longer one for 3:1 and the shorter one for 2:1 in a vertical position onto the Punch Axle. Tighten-back the Screws counter clockwise.
3. Repeat the same for Closing Handle (The shorter one).

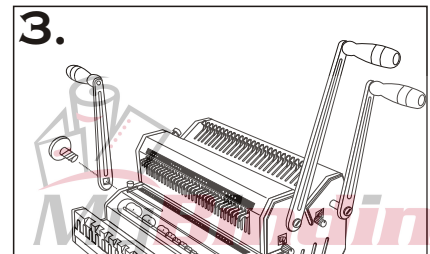
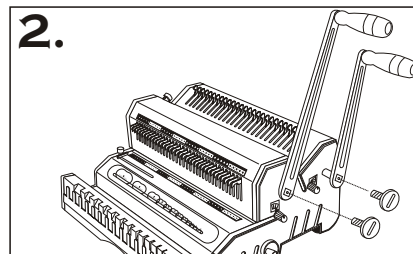
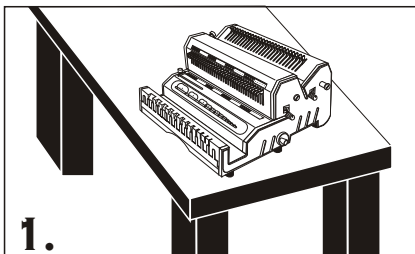

SET-UP

Insert a full unbound document into Paper Scale.

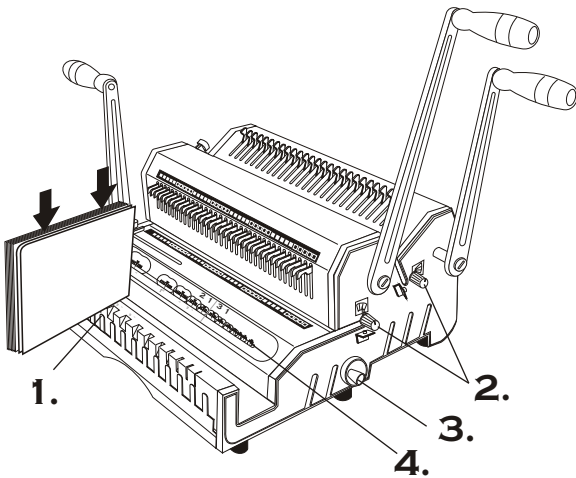

1. Read the Selector to determine the correct:
 - Punch pitch 3:1 or 2:1
 - Depth Margin
 - Wire Size
 - Wire Closure

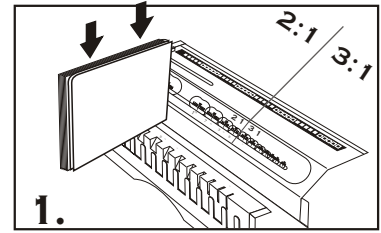

2. Set Depth Control to the color determined depth margin. Color indicated on Depth Control should match color on Selector.

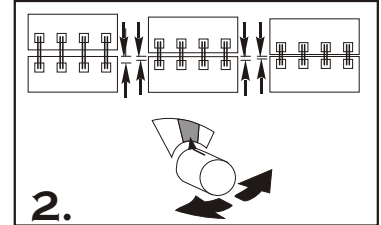

3. Set Wire Closer Control to the determined wire closure size.

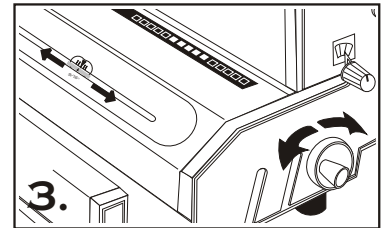

4. Read the determined wire size and set aside.

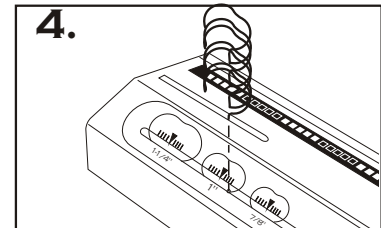

TIPS

There may be different size of 3:1 or 2:1 on some wire diameter than the standard, please make sure your on-hand wire before punching 3:1 or 2:1.

PUNCHING

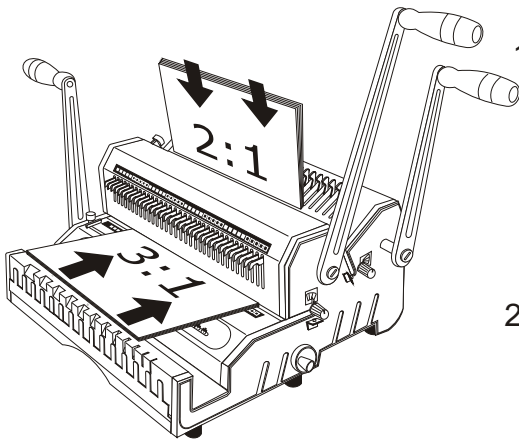

1. Move Side Margin Control to proper sheet & cover size.

Note There are different side margins for 11" sheets & their 11 1/4" Covers.

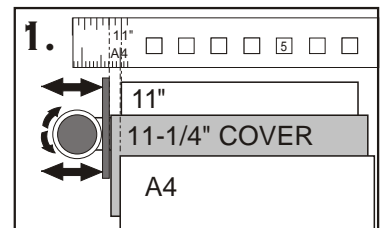

2. Pull out disengagement pins for partially covered holes.

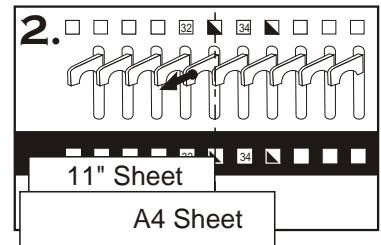

3. Insert sheets and pull handle forward to punch.

2:1 holes

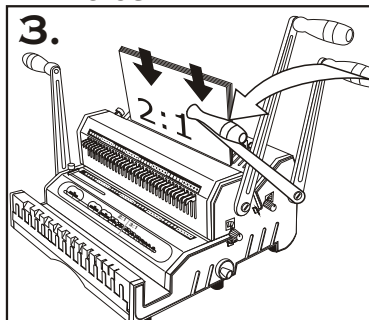

3:1 holes

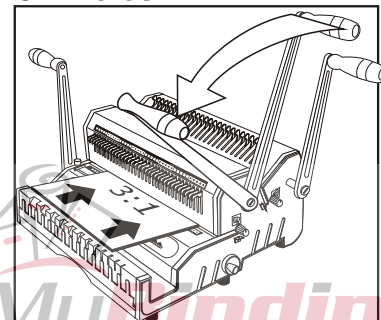

TIPS

Maximum single punching:
20 sheets of 20 Lbs
or 70-80g/m paper.

Comfortable single punching:
12-15 sheets of 20 Lbs
or 70-80 g/m paper.

Punch inner sheets and cover separately as side margin may vary.

Re-Align (Center) margins for oversize covers.

FOR PUNCHING DOCUMENT LARGER THAN 14" (356MM)

1. Align Sheets as indicated on Punch Throat Ruler. Insert sheets and pull handle forward to punch the left part first. **See Picture 1**
2. Remove sheets and flip them over as illustrated. **See Picture 2.**
3. Insert sheet from right-hand-side. Pull the handle forward and punch. **See picture 3. IMPORTANT:** Document must be inserted in such a way as to place one of the already perforated holes onto the **Continuous Punch Guide**.

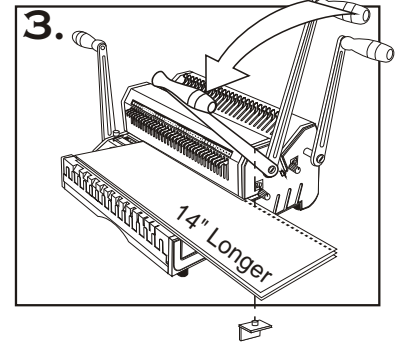
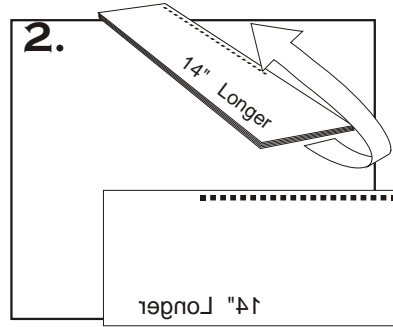
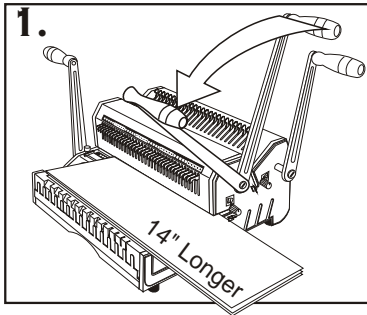

INSERTING

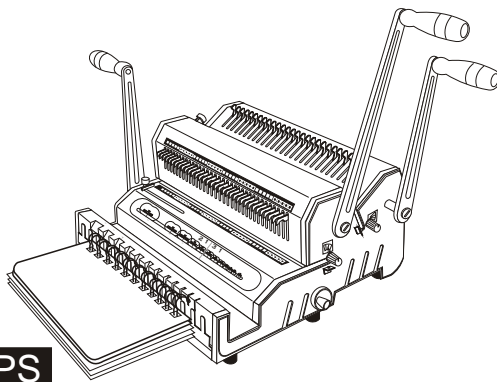

TIPS

The seam of closed wire should be inside the book. Follow step No.2 instruction for best results.

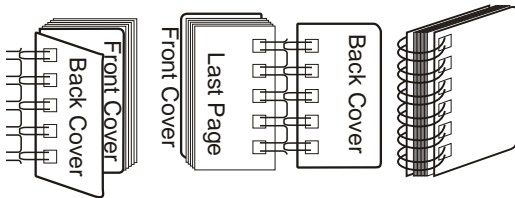

1. Insert pre-selected wire into Wire Snatch

2. Insert document from last pages to first pages then insert front cover. The back cover should be inserted last with inside facing up.

3. Take out inserted document from Wire Snatch to close the wire.

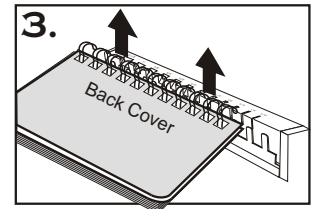
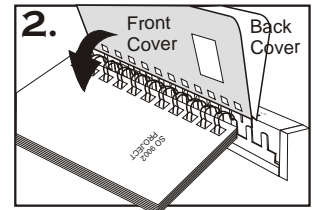
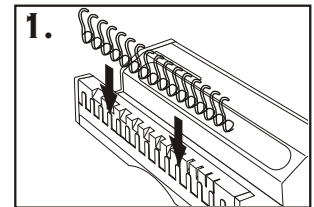

CLOSING

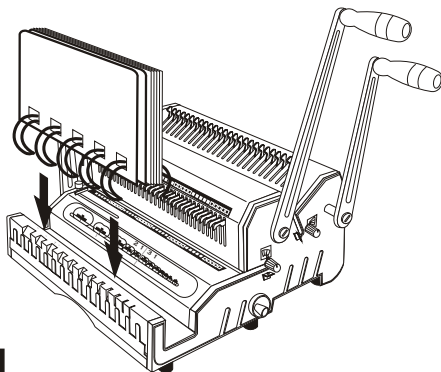

TIPS

The seam of closed wire should be just touching. Slightly adjust the Closer Control a little left or right for the under-closed or over-closed seam.

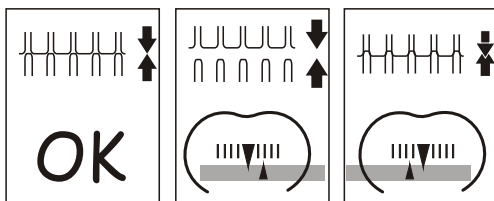

1. Put inserted document into wire closer.







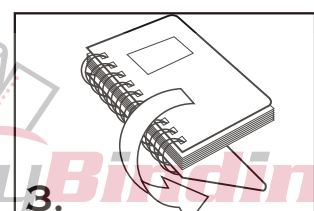
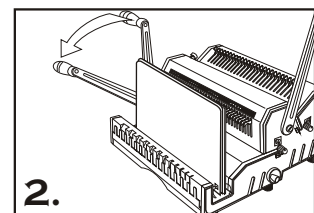
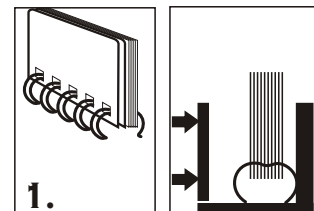

















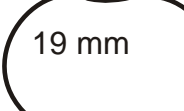

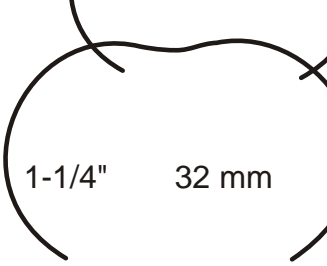

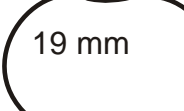

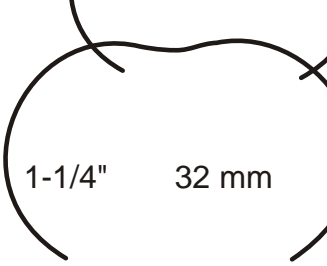
The wire element must stand horizontally at the bottom of closer.

2. Pull closer handle Forward to close.

3. Take out document and turn back cover over. The binding is ready.

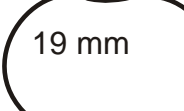

TECHNICAL INFORMATION

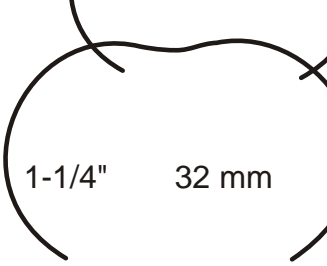
| Size | Size 3 : 1 (3 HOLES PER INCH) ■ ■ ■ ■ ■ ■ ■ ■ | Size 2 : 1 (2 HOLES PER INCH) ■ ■ ■ ■ ■ | | | | | | | | | | | | | | | | | | | | | | | | | | | | | | | | | | | | | | | | | | | | | | | | | | | | | | | | | | | | | | | | |
|----------------------------------|---|---|---|--|--|--|------|----|--|----|-------|-----|---|----|------|---|---|----|-------|---|---|----|------|---|--|----|-------|----|---|-----|------|----|---|-----|-------|----|---|---|----------------------------------|-----------|--|--|--|------|----|--|-----|------|-------|---|-----|------|-------|---|-----|------|-------|--|-----|----|-------|---|-----|--------|-------|---|
| Punching Length | 14" = 40 Holes LEGAL = 38 Holes A4 = 34 Holes 11" = 32 Holes 8.5" = 24 Holes A5 = 24 Holes | 14" = 27 Holes LEGAL = 26 Holes A4 = 23 Holes 11" = 21 Holes 8.5" = 16 Holes A5 = 16 Holes | | | | | | | | | | | | | | | | | | | | | | | | | | | | | | | | | | | | | | | | | | | | | | | | | | | | | | | | | | | | | | | | |
| Binding Capacity | <table border="1"> <thead> <tr> <th>Sheets 70-80 g/m²</th> <th colspan="2">Diameters</th> <th></th> </tr> <tr> <th></th> <th>Inch</th> <th>mm</th> <th></th> </tr> </thead> <tbody> <tr> <td>20</td> <td>3/16"</td> <td>4.5</td> <td></td> </tr> <tr> <td>30</td> <td>1/4"</td> <td>6</td> <td></td> </tr> <tr> <td>50</td> <td>5/16"</td> <td>8</td> <td></td> </tr> <tr> <td>60</td> <td>3/8"</td> <td>9</td> <td></td> </tr> <tr> <td>80</td> <td>7/16"</td> <td>10</td> <td></td> </tr> <tr> <td>100</td> <td>1/2"</td> <td>12</td> <td></td> </tr> <tr> <td>120</td> <td>9/16"</td> <td>15</td> <td></td> </tr> </tbody> </table> | Sheets 70-80 g/m ² | Diameters | | | | Inch | mm | | 20 | 3/16" | 4.5 |  | 30 | 1/4" | 6 |  | 50 | 5/16" | 8 |  | 60 | 3/8" | 9 |  | 80 | 7/16" | 10 |  | 100 | 1/2" | 12 |  | 120 | 9/16" | 15 |  | <table border="1"> <thead> <tr> <th>Sheets 70-80 g/m²</th> <th colspan="2">Diameters</th> <th></th> </tr> <tr> <th></th> <th>Inch</th> <th>mm</th> <th></th> </tr> </thead> <tbody> <tr> <td>140</td> <td>5/8"</td> <td>16 mm</td> <td></td> </tr> <tr> <td>160</td> <td>3/4"</td> <td>19 mm</td> <td></td> </tr> <tr> <td>190</td> <td>7/8"</td> <td>22 mm</td> <td></td> </tr> <tr> <td>220</td> <td>1"</td> <td>25 mm</td> <td></td> </tr> <tr> <td>280</td> <td>1-1/4"</td> <td>32 mm</td> <td></td> </tr> </tbody> </table> | Sheets 70-80 g/m ² | Diameters | | | | Inch | mm | | 140 | 5/8" | 16 mm |  | 160 | 3/4" | 19 mm |  | 190 | 7/8" | 22 mm |  | 220 | 1" | 25 mm |  | 280 | 1-1/4" | 32 mm |  |
| Sheets 70-80 g/m ² | Diameters | | | | | | | | | | | | | | | | | | | | | | | | | | | | | | | | | | | | | | | | | | | | | | | | | | | | | | | | | | | | | | | | | |
| | Inch | mm | | | | | | | | | | | | | | | | | | | | | | | | | | | | | | | | | | | | | | | | | | | | | | | | | | | | | | | | | | | | | | | | |
| 20 | 3/16" | 4.5 |  | | | | | | | | | | | | | | | | | | | | | | | | | | | | | | | | | | | | | | | | | | | | | | | | | | | | | | | | | | | | | | | |
| 30 | 1/4" | 6 |  | | | | | | | | | | | | | | | | | | | | | | | | | | | | | | | | | | | | | | | | | | | | | | | | | | | | | | | | | | | | | | | |
| 50 | 5/16" | 8 |  | | | | | | | | | | | | | | | | | | | | | | | | | | | | | | | | | | | | | | | | | | | | | | | | | | | | | | | | | | | | | | | |
| 60 | 3/8" | 9 |  | | | | | | | | | | | | | | | | | | | | | | | | | | | | | | | | | | | | | | | | | | | | | | | | | | | | | | | | | | | | | | | |
| 80 | 7/16" | 10 |  | | | | | | | | | | | | | | | | | | | | | | | | | | | | | | | | | | | | | | | | | | | | | | | | | | | | | | | | | | | | | | | |
| 100 | 1/2" | 12 |  | | | | | | | | | | | | | | | | | | | | | | | | | | | | | | | | | | | | | | | | | | | | | | | | | | | | | | | | | | | | | | | |
| 120 | 9/16" | 15 |  | | | | | | | | | | | | | | | | | | | | | | | | | | | | | | | | | | | | | | | | | | | | | | | | | | | | | | | | | | | | | | | |
| Sheets 70-80 g/m ² | Diameters | | | | | | | | | | | | | | | | | | | | | | | | | | | | | | | | | | | | | | | | | | | | | | | | | | | | | | | | | | | | | | | | | |
| | Inch | mm | | | | | | | | | | | | | | | | | | | | | | | | | | | | | | | | | | | | | | | | | | | | | | | | | | | | | | | | | | | | | | | | |
| 140 | 5/8" | 16 mm |  | | | | | | | | | | | | | | | | | | | | | | | | | | | | | | | | | | | | | | | | | | | | | | | | | | | | | | | | | | | | | | | |
| 160 | 3/4" | 19 mm |  | | | | | | | | | | | | | | | | | | | | | | | | | | | | | | | | | | | | | | | | | | | | | | | | | | | | | | | | | | | | | | | |
| 190 | 7/8" | 22 mm |  | | | | | | | | | | | | | | | | | | | | | | | | | | | | | | | | | | | | | | | | | | | | | | | | | | | | | | | | | | | | | | | |
| 220 | 1" | 25 mm |  | | | | | | | | | | | | | | | | | | | | | | | | | | | | | | | | | | | | | | | | | | | | | | | | | | | | | | | | | | | | | | | |
| 280 | 1-1/4" | 32 mm |  | | | | | | | | | | | | | | | | | | | | | | | | | | | | | | | | | | | | | | | | | | | | | | | | | | | | | | | | | | | | | | | |

WARRANTY POLICY

YOUR WIREMAC DUO HAS A WARRANTY OF ONE YEAR FROM DATE OF PURCHASE. IN THE EVENT OF A MANUFACTURER'S DEFECT, YOUR DISTRIBUTOR (AT OPTION) WILL REPAIR OR REPLACE IT. IMPORTANT: THIS WARRANTY DOES NOT COVER DAMAGES DUE TO IMPROPER USE OR MISS TREATMENT OF THE UNIT, INCLUDING ANY EXTRAORDINARY EVENT LEADING TO THE DAMAGE OF THE MACHINE, WHETHER IT IS REVERSIBLE OR NOT.

IF THE WIREMAC DUO IS NOT WORKING PROPERLY, FIRST FOLLOW THE CORRECTIVE ACTIONS ABOVE. IF THE PROBLEM PERSISTS, PLEASE CONTACT YOUR DEALER FOR FURTHER INSTRUCTIONS. PLEASE HAVE YOUR MACHINE'S SERIAL NUMBER AND THE PURCHASE DATE READY. IF THE MACHINE MUST BE RETURNED TO YOUR DISTRIBUTOR, IT IS YOUR RESPONSIBILITY TO PROPERLY PACK AND SHIP IT. AS ANY DAMAGES INCURRED DURING ITS TRANSPORTATION IS NOT COVERED BY OUR WARRANTY POLICY.

We Have it All...



MyBinding.com

When Image Matters.

Guaranteed Lowest Prices on an
Endless Selection of Binding Systems, Laminators,
Paper Shredders, Supplies and Accessories.

We have you covered with Expert Advice
and Support. Our popular blog keeps you up to
date on the latest tips and techniques to make
your most important binding and laminating
tasks a success.

Call Us Today

1-800-944-4573

Our Trusted Partners

GBC / Ibico
Fellowes
Powis Fastback
Unibind
Akiles
Renz
Tamerica
Rhin-O-Tuff
DFG

Pro-Bind
Martin Yale
MBM
Formax
Intimus
Dahle
HSM
Standard
Xyron

Challenge
Lasko-Wizer
GBC Shredmaster
Avery
Wilson Jones
Cardinal
Samsill
Universal

- BINDING MACHINES
- BINDING SUPPLIES
- LAMINATORS
- I.D. ACCESSORIES
- BOARDS & EASELS
- PAPER SHREDDERS
- XYRON LAMINATORS
- COIL BINDING MACHINES
- UNIBIND BINDING MACHINES
- FASTBACK BINDING EQUIPMENT
- PAPER FOLDING MACHINES
- LAMINATING POUCHES
- ROTARY TRIMMERS
- CLEAR COVERS
- TWIN LOOP WIRE
- REGENCY COVERS
- PLASTIC BINDING COVERS
- VELOBIND BINDING MACHINES
- PAPER HANDLING EQUIPMENT
- THERMAL BINDING MACHINES
- PROCLICK BINDING SYSTEMS
- COMB BINDING MACHINES
- COMB BINDING SUPPLIES
- WIRE BINDING MACHINES
- POUCH LAMINATORS
- LAMINATING ROLLS
- 3-RING BINDERS
- ROLL LAMINATORS
- VELOBIND SPINES
- PAPER CUTTERS
- PAPER JOGGERS
- LETTER OPENERS
- THERMAL COVERS
- UNIBIND SUPPLIES
- PROCLICK SPINES
- ZIPBIND SPINES
- LINEN COVERS
- SPIRAL COIL
- INDEX TABS

