

AKILES COILMAC M

Instruction Manual



Provided By

MyBinding.com®
When Image Matters.

CoilMac-41

CoilMac-51

OPERATIONAL MANUAL

INTRODUCTION

CONGRATULATIONS ON THE PURCHASE OF YOUR NEW *CoilMac*, A PROFESSIONAL AND HEAVY-DUTY COIL PUNCH AND BINDING MACHINE. YOUR *CoilMac* WAS CAREFULLY DESIGNED WITH A FULL RANGE OF FUNCTIONS AND PREMIUM QUALITY COMPONENTS TO GUARANTEE AN EFFORTLESS AND PROFESSIONAL BIND, AS WELL AS MANY YEARS OF TROUBLE-FREE SERVICE.

IMPORTANT

WE RECOMMEND THAT YOU TAKE A FEW MINUTES TO FAMILIARIZE YOURSELF WITH THE FUNCTIONS OF YOUR NEW *CoilMac*. YOU WILL FIND THAT WITH JUST A LITTLE PRACTICE, ANYONE CAN ACHIEVE PROFESSIONAL RESULTS.

FEATURES

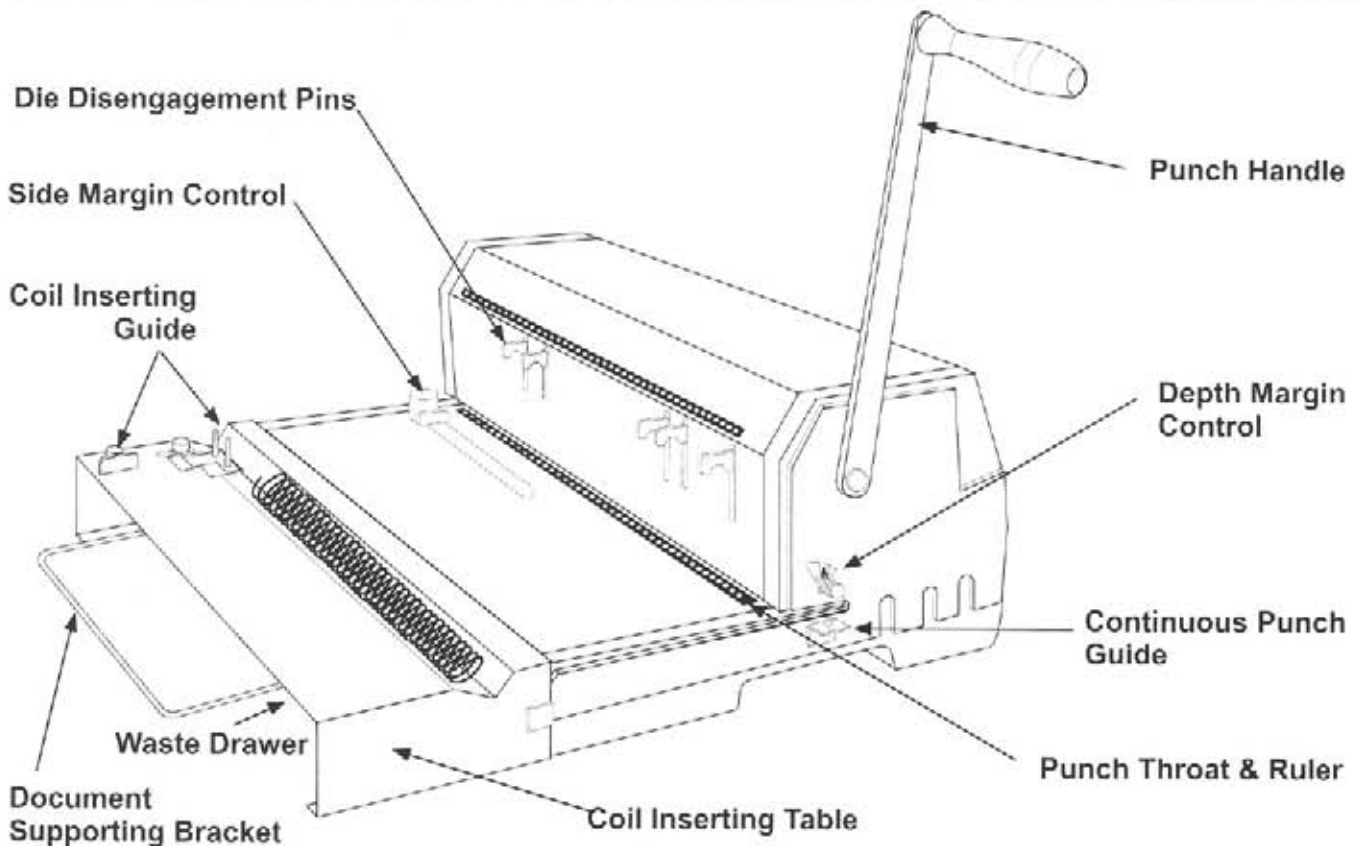

ASSEMBLY

1. Place your new *CoilMac* on top of a sturdy working table. See picture 1
2. Remove the screw from punching axle. Insert the punch handle, in a vertical position, onto the punching axle and tighten back the screw into the punching axle (make sure screw is well fastened). See picture 2
3. Attach the Coil Inserting Table to the front of your *CoilMac* or place it next to your *CoilMac*, whichever is more convenient for you. See picture 3 & 3A

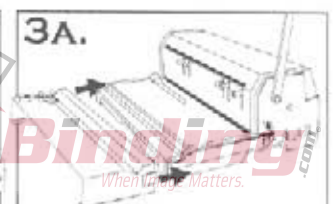
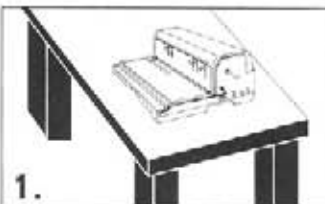

MyBinding
When It Matters.

SET-UP

1. Use Coil Size Guide to determine the correct:

- ☞ Depth Margin
- ☞ Coil Diameter

See Picture 1

2. To adjust the correct Punching Margin, press and rotate the Depth Margin Control. See Picture 2

3. (OPTIONAL) You may use the Coil Diameter Selector to determine or double check that you are using the correct coil diameter for your document. See Picture 3

HINT

To properly adjust the depth margin, press and rotate the Depth Margin Control at the same time. Release it upon reaching the desired position. **The Depth Margin Control button must bounce-back upon release.** If it does not bounce-back, rotate it slightly back and forth until it does so. See picture 4

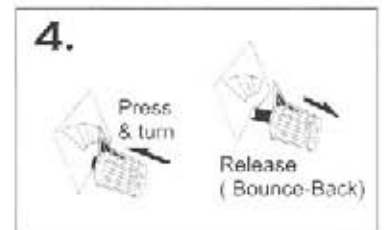
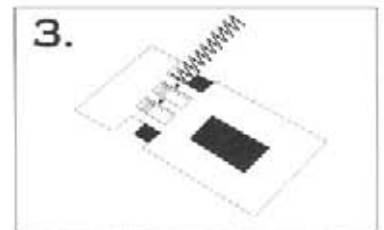
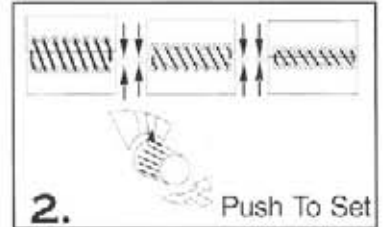
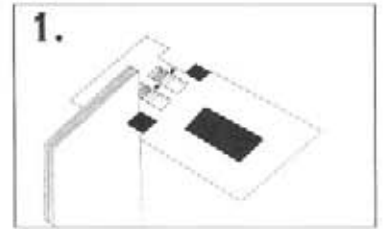

PUNCHING

1. Use the Punch Throat Ruler and Side Margin Control to center the punching of your document. See Picture 1 & 2. **HINT:** Insert a sheet and make sure you disengage any hole that is left partially exposed on the Punch Throat Ruler. Failing to do so, will leave a partially perforated hole at the edge of your document.

2. Insert sheets and pull handle toward you to punch. See picture 3

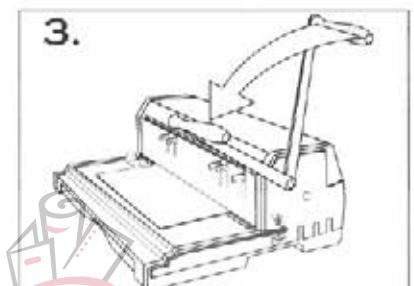
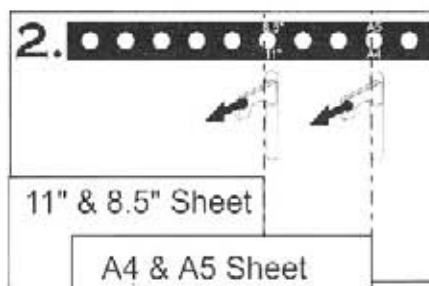
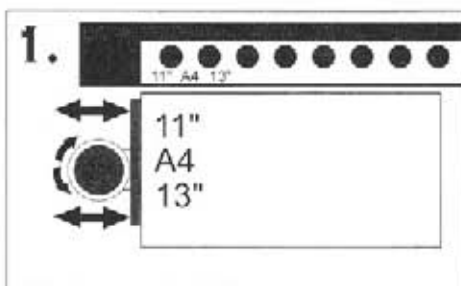

FOR PUNCHING DOCUMENT 14" (356MM) OR LARGER

1. Align Sheets as indicated on Punch Throat Ruler. Make sure all Die Disengagement Pins are pushed in.
2. Insert sheets and pull handle forward to punch. See Picture 1
3. Remove sheets and flip them over as illustrated. See Picture 2.
4. Insert sheet from right-hand-side. Pull the handle forward and punch. See picture 3.

IMPORTANT: Document must be inserted in such a way as to place one of the already perforated holes onto the **Continuous Punch Guide**. Make sure that the last hole (Document edge), if partially covered by the Punch Throat & Ruler, is aligned to a disengaged die, otherwise your document will be left partially perforated.

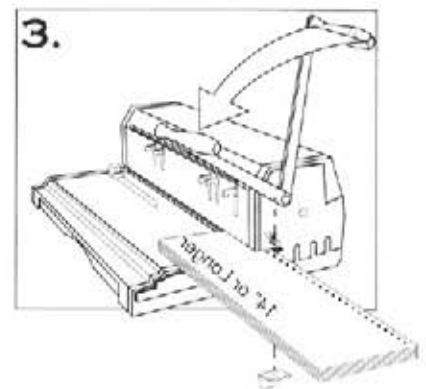
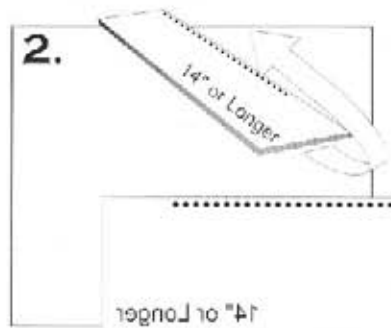
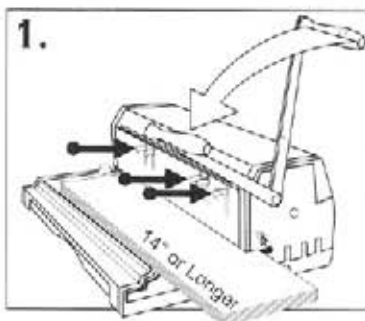

REMARKS:

- a). When using your **CoilMac** for the first time, punch a few waste sheets. This will clean-off any excess oil on the punching dies.
- b). Recommended number of sheets per punch: 12-15 (20lbs paper)
- c). Maximum recommended single punching capacity: 17 sheets (20 lbs paper)

COIL INSERTING (BINDING)

1. Place your punched document on the Coil Inserting Table. Align document and place the 1st and 4th hole on the Coil Inserting Guides. See picture 1
2. Insert coil from right-hand-side and slide hand. See picture 2
3. Upon reaching the last holes, remove document from Coil Inserting Guides and finish inserting the coil. See picture 3
4. Use a set of pliers to cut-off any excess coil. Make sure you bend-in both coil ends. This procedure will avoid document from unbinding itself. See picture 4

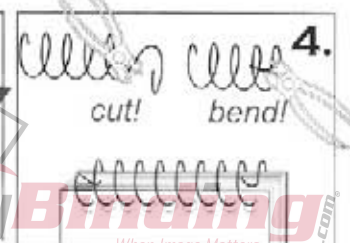
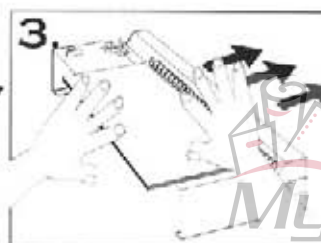
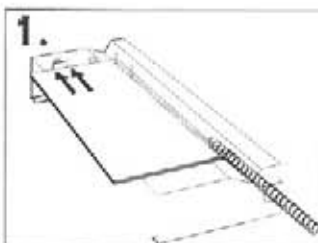

TECHNICAL INFORMATION

CoilMac-41 CoilMac-51



BINDING FORMAT

SIZE 4:1

Legal (14" or 356 mm) = 53 + 2 holes
 Oficio (13" or 330 mm) = 53 holes
 A4 (11.69" or 297 mm) = 46 holes
 Letter (11" or 279 mm) = 43 holes
 A5 (8.27" or 210 mm) = 33 holes
 1/2 Letter (8.5" or 215.9 mm) = 32 holes

SIZE 5:1

Legal (14" or 356 mm) = 65 + 5 holes
 Oficio (13" or 330 mm) = 65 holes
 A4 (11.69" or 297 mm) = 59 holes
 Letter (11" or 279 mm) = 55 holes
 A5 (8.27" or 210 mm) = 41 holes
 1/2 Letter (8.5" or 215.9 mm) = 42 holes

CAPACITY & DIAMETER

No. Sheets (20 lbs)	DOCUMENT		COIL mm	No. Sheets (20 lbs)	DOCUMENT		COIL mm
	inch	mm			inch	mm	
25	1/8"	3.2 mm	5 mm	180	3/4"	19.0 mm	20 mm
35	5/32"	4.0 mm	6 mm	200	25/32"	19.8 mm	22 mm
45	3/16"	4.8 mm	7 mm	230	7/8"	22.2 mm	25 mm
60	1/4"	6.4 mm	8 mm	250	1"	25.4 mm	28 mm
70	9/32"	7.2 mm	9 mm	280	1-1/16"	27.0 mm	30 mm
80	5/16"	7.9 mm	10 mm	300	1-1/8"	28.5 mm	32 mm
100	13/32"	10.3 mm	12 mm	350	1-5/16"	33.3 mm	38 mm
120	15/32"	11.9 mm	14 mm	400	1-9/16"	39.7 mm	45 mm
150	19/32"	15.0 mm	17 mm	450	1-7/8"	47.5 mm	50 mm

WARRANTY POLICY

YOUR *CoilMac* HAS A WARRANTY OF ONE YEAR FROM DATE OF PURCHASE. IN THE EVENT OF A MANUFACTURER'S DEFECT, YOUR DISTRIBUTOR (AT OPTION) WILL REPAIR OR REPLACE IT. IMPORTANT: THIS WARRANTY DOES NOT COVER DAMAGES DUE TO IMPROPER USE OR MISS TREATMENT OF THE UNIT, INCLUDING ANY EXTRAORDINARY EVENT LEADING TO THE DAMAGE OF THE MACHINE, WHETHER IT IS REVERSIBLE OR NOT.

IF THE *CoilMac* IS NOT BINDING PROPERLY, FIRST FOLLOW THE CORRECTIVE ACTIONS ABOVE. IF THE PROBLEM PERSISTS, PLEASE CONTACT YOUR DEALER FOR FURTHER INSTRUCTIONS. PLEASE HAVE YOUR MACHINE'S SERIAL NUMBER AND THE PURCHASE DATE READY. IF THE MACHINE MUST BE RETURNED TO YOUR DISTRIBUTOR, IT IS YOUR RESPONSIBILITY TO PROPERLY PACK AND SHIP IT. AS ANY DAMAGES INCURRED DURING ITS TRANSPORTATION IS NOT COVERED BY OUR WARRANTY POLICY.

We Have it All...



MyBinding.com

When Image Matters.

Guaranteed Lowest Prices on an
Endless Selection of Binding Systems, Laminators,
Paper Shredders, Supplies and Accessories.

We have you covered with Expert Advice
and Support. Our popular blog keeps you up to
date on the latest tips and techniques to make
your most important binding and laminating
tasks a success.

Call Us Today

1-800-944-4573

Our Trusted Partners

GBC / Ibico
Fellowes
Powis Fastback
Unibind
Akiles
Renz
Tamerica
Rhin-O-Tuff
DFG

Pro-Bind
Martin Yale
MBM
Formax
Intimus
Dahle
HSM
Standard
Xyron

Challenge
Lasko-Wizer
GBC Shredmaster
Avery
Wilson Jones
Cardinal
Samsill
Universal



- BINDING MACHINES
- BINDING SUPPLIES
- LAMINATORS
- I.D. ACCESSORIES
- BOARDS & EASELS
- PAPER SHREDDERS
- XYRON LAMINATORS
- COIL BINDING MACHINES
- UNIBIND BINDING MACHINES
- FASTBACK BINDING EQUIPMENT
- PAPER FOLDING MACHINES
- LAMINATING POUCHES
- ROTARY TRIMMERS
- CLEAR COVERS
- TWIN LOOP WIRE
- REGENCY COVERS
- PLASTIC BINDING COVERS
- VELOBIND BINDING MACHINES
- PAPER HANDLING EQUIPMENT
- THERMAL BINDING MACHINES
- PROCLICK BINDING SYSTEMS
- COMB BINDING MACHINES
- COMB BINDING SUPPLIES
- WIRE BINDING MACHINES
- POUCH LAMINATORS
- LAMINATING ROLLS
- 3-RING BINDERS
- ROLL LAMINATORS
- VELOBIND SPINES
- PAPER CUTTERS
- PAPER JOGGERS
- LETTER OPENERS
- THERMAL COVERS
- UNIBIND SUPPLIES
- PROCLICK SPINES
- ZIPBIND SPINES
- LINEN COVERS
- SPIRAL COIL
- INDEX TABS