

Akiles BookletMac Booklet Making Machine

Instruction Manual



Provided By

MyBinding.com
When Image Matters.

Troubleshooting

Machine is switched on, but it won't work at all.

The power cord is not plugged in properly.	Push power cord thoroughly into power outlet.
Cover is open.	Close cover.
No-Staple light is ON.	Re-fill Staples. Follow instructions on Page 5.
Papers are not in Paper-in tray.	Place paper on Paper-In Tray and align to the Left & Right Side Guides.
Staples jam.	<ol style="list-style-type: none"> 1. Remove jammed staples. Follow instructions on page 4. 2. Always use our 26/6 or 26/8 standard staples. 3. Check if Staples Pusher is scratched or worn out. Follow instructions on page 4 to put in a new Staples Pusher.
Paper Jam.	<ol style="list-style-type: none"> 1. To remove jammed sheets, press the "REVERSE" button on control panel to drive paper backward. You may need to press it a few times until it stops, then you can pull out jammed sheets. 2. Do not insert more than 20 sheets of 20 lbs paper. 3. Do not insert materials that are too thick or too rigid sheets. Do not insert materials other than papers.
Black (Dark colored) Covers.	If possible, avoid using black or dark colored covers, as the infrared sensor may not be able to detect sheets being inserted into the machine.

Machine does not staple although the staple magazines are fully filled with staples.

Staple Pusher is not hinged onto the pin.	The hole on the Staple Pusher should be hinged onto the pin. Follow instructions on Page 4.
Staple Pusher is missing or incorrectly positioned.	Follow instructions on Page 4 to put in Staples Pusher. The mark "26" should be shown towards the rear of the machine and the Stapler Head latch should be locked.

Missing staples or un-qualified staple output.

Unqualified staples.	Use only our standard 26/6 & 26/8 staples. See page 5.
Incorrect staples type or specification.	Use only our standard 26/6 & 26/8 staples. See page 5.
Stapler Pusher is put in the wrong direction.	The Stapler Pusher should be shown towards the rear of the machine. See Page 4
Residues inside Stapler Head.	Remove the Stapler Head from the machine, unscrew the front plate of Stapler Head, clean Stapler Head and re-install the Stapler Head to the machine. Make sure the Stapler Head latch is locked before you operate the machine. Follow the instructions on Page 4 to remove/install Stapler Heads.
Stapler Pusher is scratched or worn out.	Follow the instructions on Page 4 to change Staples Pusher.

Cannot fold or un-qualified booklet fold & staple.

Settings for the Fold & Staple features are not correctly set.	Follow instructions on page 3 to set-up the Fold & Staple features correctly.
Too many sheets are inserted or the material is too rigid.	<ol style="list-style-type: none"> 1. Do not insert more than 20 sheets of 80 lbs paper per run. 2. Do not insert materials that are too thick or too rigid sheets. Do not insert materials other than papers.
Folding line is not located in the center of the booklet, or is at a slanted angle.	<ol style="list-style-type: none"> 1. Properly adjust the Left & Right Side Guides. If the Side Guides are too far apart, paper can be unparallel as it is inserted into the machine. On the other hand, if the Side Guides are set too tightly, paper can curl up during folding, which results in incorrect stapling. See Page 6 for instructions. 2. Properly adjust the Paper Depth Adjustment Knob, so the machine folds in the center of the sheets. See Page 6 for instructions.
Dirty rollers.	Clean rollers by soft and damp cloth. Never use chemical or alcohol base liquids as they may damage the roller.
The 2 staples are not properly centered in the booklet.	<ol style="list-style-type: none"> 1. Properly adjust the Left & Right Side Guides. See Page 6. 2. Re-install Stapler Heads to the correct positions. See page 4.

WARRANTY POLICY

Your **BookletMac** has a warranty of one year from date of purchase. In the event of a manufacturer's defect, your distributor (at option) will repair or replace it. Important: this warranty does not cover damages due to improper use or miss treatment of the unit, including any extraordinary event leading to the damage of the machine, whether it is reversible or not. If the **BookletMac** is not working properly, first follow the trouble shooting above. If the problem persists, please contact your dealer for further instructions. Please have your machine's serial number and the purchase date ready. If the machine must be returned to your distributor, it is your responsibility to properly pack and ship it. As any damages incurred during its transportation is not covered by our warranty policy.

BookletMac OPERATIONAL MANUAL

INTRODUCTION

Congratulations on the purchase of your new **BookletMac**, a professional and heavy-duty booklet making machine. Your **BookletMac** was designed with a full range of function and premium quality components to guarantee you an effortless and professional job, as well as many years of trouble-free services.

IMPORTANT

We recommend that you take a few minutes to familiarize yourself with the functions of your new **BookletMac**. You will find that with just a little practice, any person can achieve professional results.

FEATURES

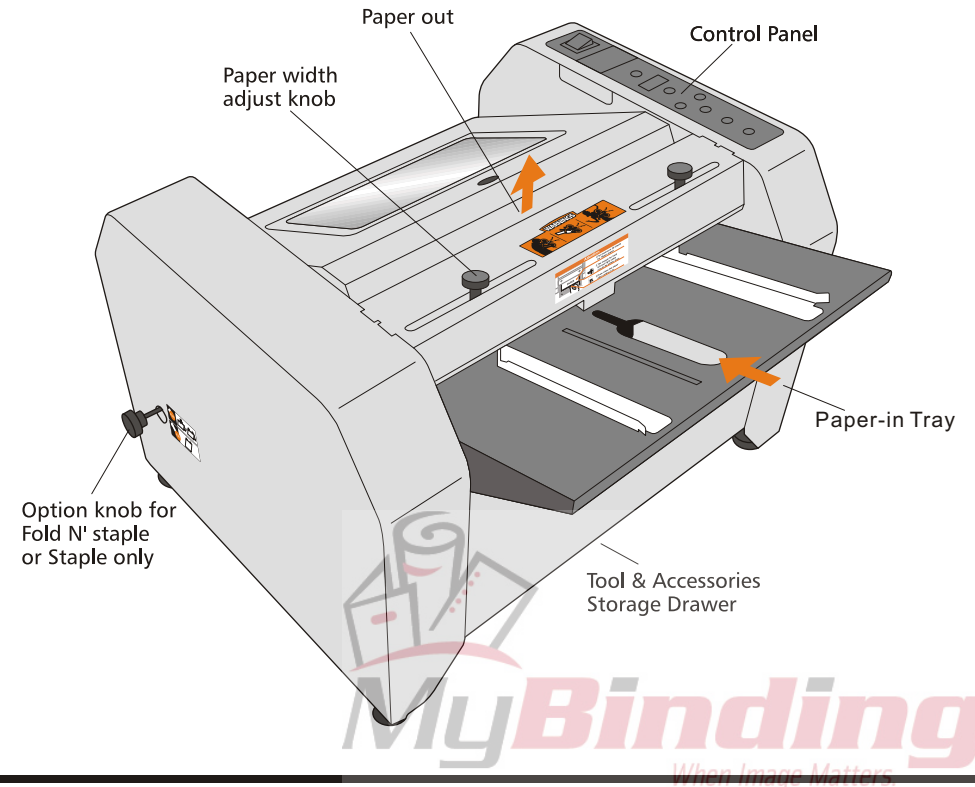

ASSEMBLY & SAFETY

1. Place your new **BookletMac** on top of a sturdy working table.
2. Plug the power cord to the back of machine.
3. To reduce the risk of electric shock, never operate the **BookletMac** near water.
4. Do not use the **BookletMac** if power cord is damaged.
5. Do not allow the electric cord to be in contact with hot surfaces.
6. In case of malfunction, return the unit to your distributor for service. This equipment does not contain any part that can be serviced by the consumer or operator.

OPERATION INSTRUCTIONS

1. Keep fingers, hair, jewelry, necktie and any loose clothing or objects away from the machine, as they may be accidentally pulled inside.
2. As part of its safety features, your BookletMac is equipped with sensors in various places of the machine. As a result, the machine will not work when the cover is open, the paper is not in position and no staple is inside the Stapler Head.
3. Clean the machine only by soft and damp cloth. Never use the chemical or alcohol base liquids as they may damage the rubber rollers or surface of your machine.
4. Lubricate the machine from time to time following the illustration below (lubricant is included in the tools drawer).
5. Only use our standard staples as others may damage your BookletMac.

Electricity

- 115VAC / 60Hz
- 230VAC / 50Hz

Tools & accessories delivered with this machine.

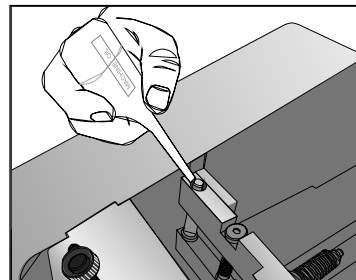
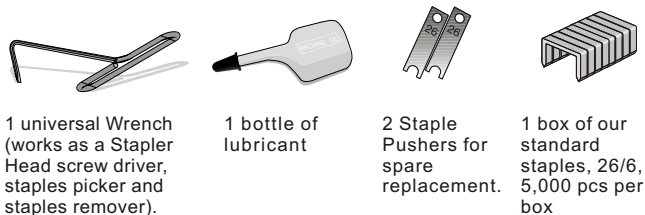

SET UP FOR FOLD & STAPLE

1. To make a booklet with folding line in the middle and then stapled, push 2 knobs down as shown in picture 1.
2. To make a booklet with staples only without any folding, set 2 knobs as shown picture 2.
3. To have paper just folded without any stapling, push 2 knobs down as picture 1 but just without staples loaded into Stapler Heads.

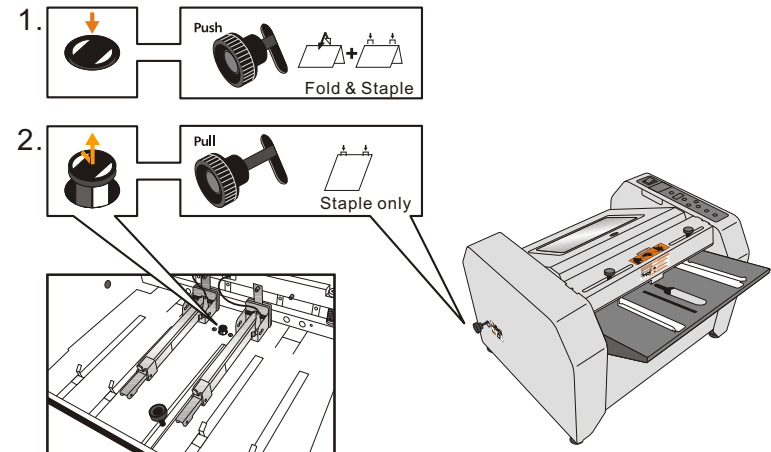

SET UP FOR STAPLER HEADS

The **BookletMac** comes with 2 **Stapler Heads** positioned at 80mm apart from each other, which is suitable for most booklet formats from 5-1/2"x 4-1/4" (or A6 size) up to Letter size (or A4 size). For booklets larger than Letter size, you can choose to purchase 1 or 2 more **Stapler Heads**, or set your **Stapler Head** positions further apart, for a more secure and professional booklet. Contact your dealer for more information. Follow the steps in next page to install / remove **Stapler Heads**.

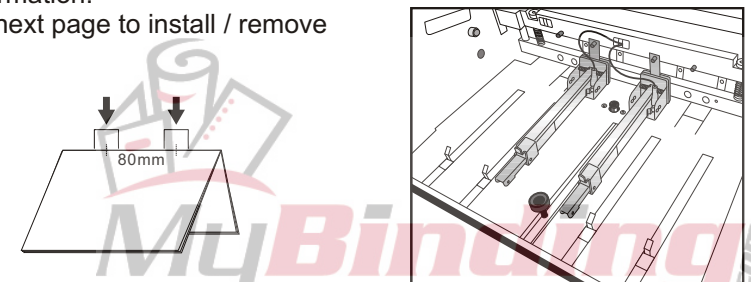
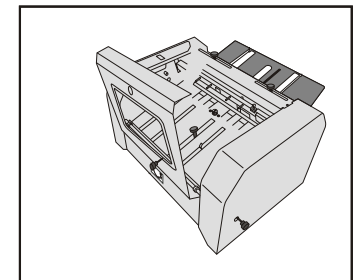

MOVE STAPLER HEADS

Following the steps below if you wish to remove/install **Stapler Heads** at different positions.

- Turn the latch counter-clockwise to position 1. to unlock the **Stapler Head**.
Unplug the cord socket from **Stapler Head**.
- Remove **Stapler Head** and insert it in a different **Stapler Head** position.
- Make sure the hole on **Staples Pusher** is hinged onto the pin, and the mark "26" on the **Staple Pusher** is shown towards the rear of the machine. Turn the latch clockwise to lock it, and plug in the cord socket back to **Stapler Head**.

IMPORTANT:

- To avoid problems during operation, the hole of the **Staples Pusher** must be hinged onto the pin, with the mark "26" shown towards the rear of the machine.
- The latch must be securely locked onto **Stapler Head**. Otherwise, the **Stapler Head** may fall out during operation and cause the machine to be seriously damaged

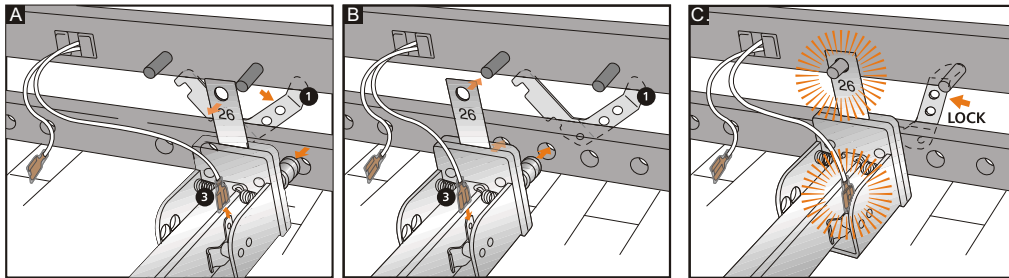

TIPS to remove jammed staples from Stapler Heads.

Repeat the above steps to remove **Stapler Head** from machine, then use the **Universal Wrench** to unscrew the front plate of **Stapler Head**. Remove jammed staples and clean it. Screw the front plate back onto the **Stapler Head**. Repeat above steps to install **Stapler Head** back to machine.

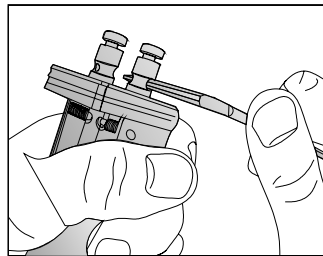

TIPS to replace new Staples Pusher

The **Staples Pusher** should be replaced from time to time to ensure an efficient and smooth stapling operation. If staple jams occur more frequently than usual, or a abnormal stapling sound occurs during operation, follow the steps above to remove **Staples Pusher** and check if it is scratched or worn out. To purchase new **Stapler Pusher** (Part # CS2-80-3), contact your dealer. Then, follow the steps as above to replace the **Staples Pusher**.

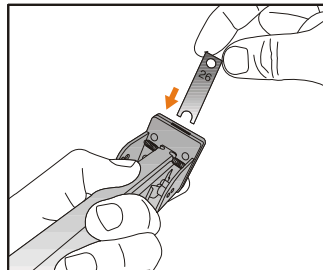

LOAD STAPLES

- Pull the staples magazine cap backwards until it is locked in place.
- Open staples magazine cover.
- Load staples (Must use our standard 26/6 or 26/8 staples).
- Close magazine cover and gently unlock the staples magazine cap and push it towards the machine's front side. Do not let the staples magazine cap to snap forward, as it would smash the stick of staples.

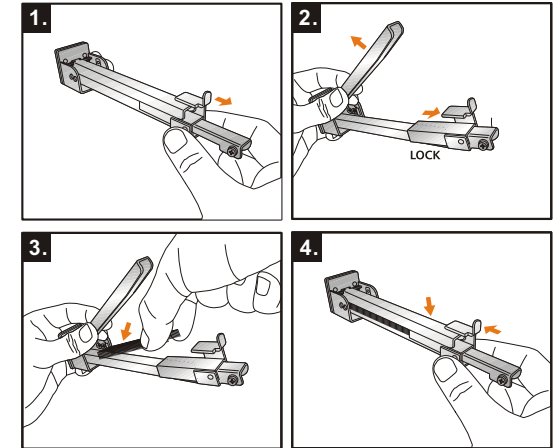

IMPORTANT:

Use only our standard staples on the right. Other Staples may damage our Stapler Head or lead to bad results.

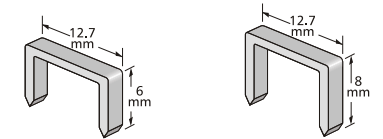

Part # SC 266,
26/6 Staples
5,000 pcs/box

Part # SC 268,
26/8 Staples
5,000 pcs/box

The No-Staple light will be turned ON when there are only 5 staples left in the Staples Magazine. Also, machine will stop working at this point. Remove last left 5 staples and refill staples to stapler magazine following the above instructions (Maximum 210 staples per load).

TIPS

Some defective staples may fall inside of machine. Use the magnetic **Universal Wrench** to pick them up from inside of the machine as needed.

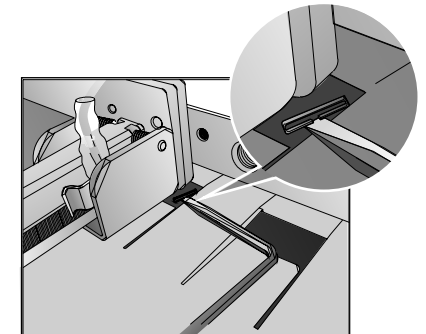

Our **Universal Wrench** can also be used as a staples remover.



ADJUST PAPER WIDTH & LENGTH

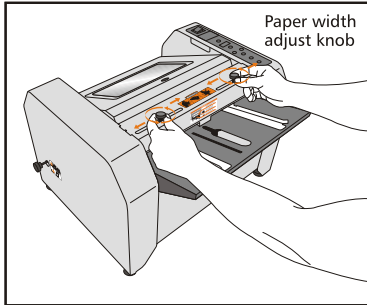

Paper width adjust knob

1. Adjust the **Left Side Guide** to the proper position on the paper scale sticker, according to your sheet format. Secure it with the knurled screw.
2. Insert paper, then squaring it up parallel to the **Left Side Guide**.
3. Adjust the **Right Side Guide** next to the inserted paper, leaving approximately 1mm of space so that the paper can slide in and out easily & smoothly.

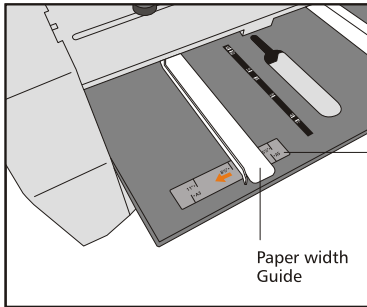

Paper width Guide

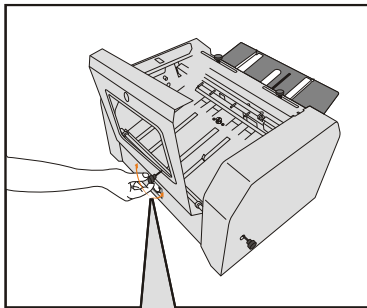
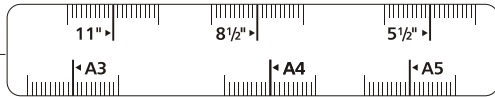

- To adjust the Paper Length.
1. Open the machine cover and adjust Paper Depth Adjustment Knob to the proper position, according to your sheet size. Then close cover to test fold a few sheets manually.
 2. Center the folding line of your booklet by turning the Paper Depth Adjustment Knob and making small adjustment on it.

- Minimum sheet sizes: A5 (or 5.5" x 8.5")
- Maximum sheet sizes: A3 (or 11" x 17")
- Minimum of booklet sizes: A6 (or 5.5" x 4.25")
- Maximum of booklet sizes: A4 (8.5" x 11")

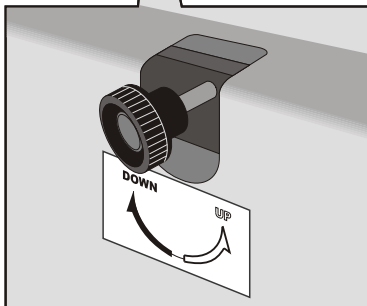

FEEDING PAPERS

1. Insert flat sheets at **Paper-in Tray** and align it to the **Left & Right Side Guides**, making sure the sheets are squared up correctly. Press "**MANUAL START**" button on control panel, then the sheets will be slide into the machine and booklet will be produced from **Paper-out**.

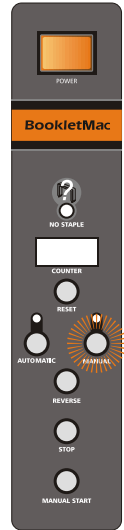
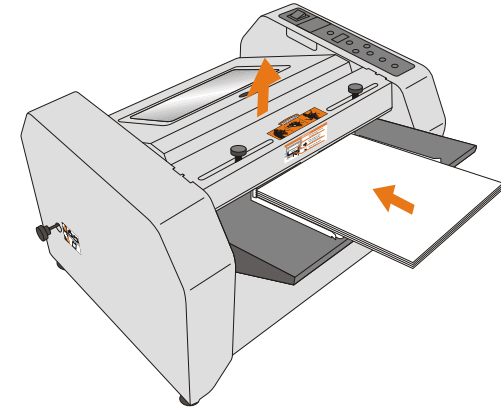

2. Make slight adjustments to the **Left & Right Side Guides, Paper Depth Adjustment Knobs** or **Stapler Head positions** until the satisfactory booklet come out. Then press the "**AUTOMATIC**" button and reset the "**COUNTER**" to zero, so you can feed in papers continuously. **NOTE:** When the operation mode is set on **AUTOMATIC**, machine will start automatically in 2 seconds after sheets are inserted into the **Paper-in Tray**.

- Allows maximum 20 sheets of 70 gsm paper per run.
- Productivity: up to 800 booklets per hour.

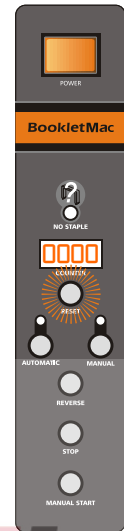
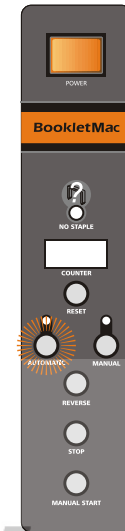

We Have it All...



MyBinding.com *When Image Matters.*

Guaranteed Lowest Prices on an
Endless Selection of Binding Systems, Laminators,
Paper Shredders, Supplies and Accessories.

We have you covered with Expert Advice
and Support. Our popular blog keeps you up to
date on the latest tips and techniques to make
your most important binding and laminating
tasks a success.

Call Us Today

1-800-944-4573

Our Trusted Partners

GBC / Ibico

Fellowes

Powis Fastback

Unibind

Akiles

Renz

Tamerica

Rhin-O-Tuff

DFG

Pro-Bind

Martin Yale

MBM

Formax

Intimus

Dahle

HSM

Standard

Xyron

Challenge

Lasko-Wizer

GBC Shredmaster

Avery

Wilson Jones

Cardinal

Samsill

Universal



- BINDING MACHINES
- BINDING SUPPLIES
- LAMINATORS
- I.D. ACCESSORIES
- BOARDS & EASELS
- PAPER SHREDDERS
- XYRON LAMINATORS
- COIL BINDING MACHINES
- UNIBIND BINDING MACHINES
- FASTBACK BINDING EQUIPMENT
- PAPER FOLDING MACHINES
- LAMINATING POUCHES
- ROTARY TRIMMERS
- CLEAR COVERS
- TWIN LOOP WIRE
- REGENCY COVERS
- PLASTIC BINDING COVERS
- VELOBIND BINDING MACHINES
- PAPER HANDLING EQUIPMENT
- THERMAL BINDING MACHINES
- PROCLICK BINDING SYSTEMS
- COMB BINDING MACHINES
- COMB BINDING SUPPLIES
- WIRE BINDING MACHINES
- POUCH LAMINATORS
- LAMINATING ROLLS
- 3-RING BINDERS
- ROLL LAMINATORS
- VELOBIND SPINES
- PAPER CUTTERS
- PAPER JOGGERS
- LETTER OPENERS
- THERMAL COVERS
- UNIBIND SUPPLIES
- PROCLICK SPINES
- ZIPBIND SPINES
- LINEN COVERS
- SPIRAL COIL
- INDEX TABS